

TOWN OF POOLESVILLE
POOLESVILLE, MARYLAND

Technical Specifications and Standard Drawings

for

Kohlhoss Water Line Replacement

Contract No. 100.062

INVITATION TO BID

THE COMMISSIONERS OF POOLESVILLE
A Municipal Corporation of the State of Maryland

for

TOWN OF POOLESVILLE
KOHLSHOSS WATER LINE REPLACEMENT
CONTRACT NO. 100.062

Sealed bids for the construction of the Project named above should be addressed to the Commissioners of Poolesville and will be received at Poolesville Town Hall, P.O. Box 158, 19721 Beall Street, Poolesville Maryland 20837, until the time set forth below at which place and time they will be publicly opened and read.

DESCRIPTION OF BASE PROJECT

The project involves the replacement of approximately 3,500 linear feet of water line and connecting to the existing laterals that are connected to the existing water main. Patching of the excavated sections of roadway and stabilization of grass areas as needed

All work will be constructed in the Town of Poolesville, located in Montgomery County, Maryland.

Pre-Bid Meeting Date: February 8, 2024

Time: 1:00 p.m.

Location: Poolesville Town Hall
19721 Beall Street, Poolesville, MD 20837

Last Day for Questions: February 15, 2024

4:00 p.m.

Bid Opening Date: February 26, 2024

Time: 11:30 a.m.

Location: Poolesville Town Hall
19721 Beall Street, Poolesville, MD 20837

All Contract Documents and Addendums will be posted to eMaryland Marketplace Advantage. It is the bidders' responsibility to refer to eMMA for updates and addendums.

Bidder qualification requirements and labor provisions are set forth in the Information for Bidders. Contract for work under this bid obligates the Contractor and Subcontractors not to discriminate in employment practices.

Wade Yost, Town Manager

TABLE OF CONTENTS

INVITATION TO BID	ITB-1
INFORMATION FOR BIDDERS	IFB-1
GENERAL CONDITIONS.....	GC-1
SPECIFICATIONS	
DIVISION 1 - GENERAL REQUIREMENTS	
Submittal Procedures	01330-1
DIVISION 2 – SITE WORK	
Clearing and Grubbing.....	02100-1
Earthwork	02200-1
Pavement and Concrete	02515-1
Water Distribution System	02660-1
Lawns and Grasses.....	02930-1
BID FORM AND ENCLOSURES	
Bid Bond	BF-1
Affidavit of Non-Conviction	BF-3
Bid Form (Proposal)	BF-4
Price Schedule.....	BF-6
Contractor's Qualification Statement.....	BF-7
Form For Substitutions For Specified Items	BF-9
Acknowledgement of Addenda	BF-10
AGREEMENT AND BONDS	
Agreement	AGR-1

INFORMATION FOR BIDDERS

I. BIDDING PROCEDURE

A. Submitting A Proposal

1. Before submitting a Proposal, each Bidder shall carefully read the Specifications and Contract Documents, visit the site of the Work, be fully informed of all conditions and limitations, and include sums in the Bid to cover the cost of all items contained in the Contract. Site visits and opportunities to examine the existing structure may be coordinated by contacting John Strong at (240) 912-3492 or jstrong@clarkazar.com.
2. All Proposals must be submitted upon the attached form and must give the lump sum Contract Price, written in words and shown in figures, for performing the Work under this Contract.
3. All Proposals must be signed by the Bidder with name and address. The Proposals must be enclosed in a sealed envelope marked " **Kohlhoss Waterline Replacement for Contract 100.062**" with the name of the Bidder.
4. The Owner reserves the right to reject any and all bids and the right to disregard any or all non-conforming or conditional bids or counter bids.
5. Bids may be modified in writing or withdrawn at any time prior to the opening of Bids. Oral, telephonic, or telegraphic Bids are invalid and will not receive consideration.
6. Bidders are advised that, unless Work under the Contract is started within ten (10) days after receipt of the formal Notice to Proceed with the Work, the Contract shall be void if the Owner notifies the Contractor to that effect.
7. A bid bond, certified check or bank treasurer's check in the amount of five percent of the base bid price must accompany the Bid Form, or the same will not be considered.
8. Bidders shall have the capability to perform classes of work contemplated and shall have the necessary plant and sufficient capital to execute the Work properly within the specified time frame. All bidders shall complete and submit the Contractor's Qualification questionnaire (Bid Form Section) with their proposal.
9. Bidder shall assume full responsibility for timely delivery at Town Hall. Bids received after the designated time for the public bid opening will be returned to the bidder unopened.
10. Bids will be publicly opened and read aloud at the time and place set forth in the Invitation to Bid. Only bid totals will be publicly read at the Bid Opening. Bidders and other interested parties may be present in person or by representative.
11. No Bidder may withdraw a Bid within ninety (90) days after the actual date of the opening of the Bids. Negligence on the part of the Bidder in preparing the Bid

confers no right for the withdrawal of the Bid after it has been opened. Should there be reasons why the Contract cannot be awarded within the specific period, the time may be extended by mutual agreement between the Town and the Bidder.

12. A bidder may submit only one Bid for this Contract. More than one Bid from an individual, firm or partnership, corporation or association under the same or different names will not be considered for this Contract and will be considered grounds for disqualification of the Bids involved.
13. If the Town chooses to award this Contract it will be awarded to the lowest, responsible, responsive bidder. The Owner shall be the sole judge of which proposal is deemed the most responsive.

B. Work Under this Contract

1. Work described herein shall be in accordance with the General Conditions, Proposal, Technical Provisions, Attachments, and other documents contained in the Contract Documents.

C. Notice to Bidders

1. Foreign Corporations: As required by Maryland Law, all foreign corporations doing business within the State of Maryland are required to be registered with the State Department of Assessments and Taxation. In order to be eligible to contract with the Owner, compliance with this law is mandatory.
2. Affidavit of Non-Conviction: Maryland laws require an affidavit by the Bidder as to whether or not the individual or the business entity has ever been convicted of bribery in the State of Maryland or elsewhere. Bidders must complete the form, "Affidavit of Non-Conviction". The completed form must be submitted with the Bid.
3. The Owner will consider, in determining the qualifications of the Bidder, its record in the performance of any contracts for the construction work into which it may have entered with the Town or with other public bodies or corporations. The Owner expressly reserves the right to reject the bid of any Bidder if such record discloses that such Bidder, in the opinion of the Owner, has not properly performed such contracts or has habitually and without just cause neglected the payment of bills, or has otherwise disregarded its obligations to Subcontractors, material men, suppliers or employees.
4. The Owner may make such investigations as it deems necessary to determine the ability of the Bidder to perform the work, and the Bidder shall furnish to the Owner all such information and data for this purpose as it may request. The Owner reserves the right to reject any bid if the evidence submitted by, or investigation of such Bidder, fails to satisfy the Owner that such Bidder is a responsive and responsible Bidder in accordance with the criteria set forth herein. Conditional bids will not be accepted.
5. Affidavit of Non-Collusion: The Owner is cooperating with the U.S. Department of Justice in a program designed to preclude collusive bidding and to

make more effective the enforcement of antitrust laws in the area of procurement of property and services by governmental and public agencies. Bidders must supply with their Bids their U.S. Treasury Department Employer's Identification Number as such number is shown on their Employment Quarterly Federal Tax Return (U.S. Treasury Department Form No. 941). This number shall be inserted on the Proposal in the place designated.

D. Interpretation of Documents

1. If any person contemplating submitting a Bid for the proposed Contract is in doubt as to the true meaning of any part of the Specifications or other sections of the Contract Documents or finds discrepancies in or omissions from the Specifications, he may submit to **John Strong, Clark | Azar & Associates, 20440 Century Blvd, Suite 220 Germantown, MD 20874 (240)-912-3492, email jstrong@clarkazar.com**, a written request for an interpretation or correction thereof. The person submitting the request will be responsible for its prompt delivery.

Questions received after 4:00 p.m. February 15, 2024 will not be answered. Any interpretation or correction of the proposed Documents will be made only by an Addendum duly issued, and a copy of such Addendum will be sent, by certified mail, to each person having a set of such Documents in their possession. The Owner will not be responsible for any other explanations or interpretations of the Contract Documents.

2. Any and all Addenda issued prior to the date of Bid submission shall become a part of the Contract Documents and shall be covered in the Bid price.

E. Taxes

1. The Contractor shall pay all Federal, State and local taxes for equipment, materials and other items required for this Contract.

F. Equal Employment Opportunity and Non-Discrimination

1. All Contractors and subcontractor working for the Town of Poolesville must comply with the following:
 - a. All Civil Rights laws of the United States and of the State of Maryland;
 - b. All anti-age discrimination laws of the United States and the State of Maryland;
 - c. All anti-sex discrimination laws of the United States and the State of Maryland;
 - d. All anti-handicapped discrimination laws of the United States and the State of Maryland.

G. Construction Schedule

1. Within ten (10) days after the issuance of the Notice of Award, the Contractor shall submit his construction schedule to the Engineer for review and approval.

II. AWARD OF CONTRACT

A. Performance, Payment and Maintenance Bonds

1. The successful bidder shall furnish Performance and Payment Bonds and a letter of intent to issue a Maintenance Bond to the Owner in penal sums equal to 100 percent of the amount of the Contract.
2. The Bidder to whom the Contract is to be awarded shall be required to submit the Performance and Payment Bond, properly executed, to the Owner within ten (10) days after award of the Contract. No Bid shall be considered binding upon the Owner until the Contract has been awarded and all Bonds have been received.
3. Upon satisfactory completion of the work, the Contractor shall furnish to the Owner a Maintenance Bond to be in effect for a period of one year from Contract Final Acceptance.

B. Execution of the Contract

1. The Contract will be awarded by the Owner within ninety (90) days of the Bid opening date to the most responsive and responsible Bidder or the Bids may be rejected as hereinbefore provided, as the interests of the Owner may require. The Bid as submitted shall serve as the final Contract acceptance document.
2. The Owner will retain all bid bonds until the Contract has been awarded at which time they will be returned.
3. Formal Notice to Proceed will be issued by the Owner within thirty (30) days of the Contractor's submission of the insurance certificates and bonds as specified in the General Conditions and its Supplements.
4. All Work under this Contract, including cleaning up, shall be fully completed within the number of calendar days specified in the Contract.
5. Prior to starting work on this Contract, a pre-construction meeting will be held at the site to review requirements of the Contract. Progress meetings will be held at the Engineer's discretion.
6. Consideration of and decisions regarding substitutions will not be made until after Award of the Contract.
7. The Owner wishes to construct all of the improvements depicted in these bid documents. However, project-funding limitations may prohibit the Owner from proceeding with all of the proposed work.

III. BIDDER REPRESENTATIONS

Each bidder by submitting a bid represents that:

- A. It has read and understands the Bidding Documents and its Bid is made in accordance therewith; the Bidder agrees to be bound by the terms and requirements set forth in the Bidding and Contract Documents.
- B. It has visited the site, has familiarized itself with the local conditions under which the work is to be performed and has correlated its observations with the requirements of the proposed Contract Documents.
- C. Its bid is based upon the materials, systems and equipment required by the Bidding Documents without exception; and
- D. It has the capability, in all respects, and the moral and business integrity, reliability, technical ability, financial resources, plant, management, superintendence, equipment and materials which will assure effective and efficient good faith performance in full compliance with the Contract Documents and with any and all schedules and Milestone and Complete dates required by the Owner. The Bidder acknowledges and represents that it has made allowances for normal inclement weather indigenous to the Project Site, in its estimating, planning and scheduling of the work. The Bidder further acknowledges that the Contract Documents are, in its opinion, appropriate and adequate for completing this project and for the construction of sound and suitable work. The Bidder hereby certifies that the work shall be completed, in place, in full accordance with the Contract Documents, within the time limits specified.

IV. BID EVALUATION

- 1. Bids will be evaluated based upon the total Contract Prices provided by Bidders on Page BF-4.
- 2. Bids will also be evaluated on the performance of previous similar contracts by a Bidder for the Owner. Unsatisfactory performance on previous contracts is considered grounds for rejection of a bid.

* * *

GENERAL CONDITIONS

Article 1. DEFINITIONS

- 1.1 Wherever used in the Contract Documents, the following terms shall have the meanings indicated, which shall be applicable to both the singular and plural thereof.
- 1.2 Addenda - Written or graphic instruments issued prior to the Award of the Contract which modify or interpret the Contract Documents, Drawings and Specifications by additions, deletions, clarifications or corrections.
- 1.3 Bid - The offer or proposal of the Bidder submitted in the prescribed manner on the prescribed form setting forth the prices for the Work to be performed.
- 1.4 Bidder - Any person, firm or corporation submitting a Bid for the Work.
- 1.5 Bonds - Bid Bonds, Performance Bonds, Labor and Material Payment Bonds, Maintenance Bonds, and other instruments of security furnished by the Contractor and his surety in accordance with the Contract Documents.
- 1.6 Change Order - A written order to the Contractor signed by the Engineer authorizing an addition, deletion or revision in the work within the general scope of the Contract Documents, or authorizing an adjustment in the Contract Price or Contract Time.
- 1.7 Contract Documents - The Contract, including Invitation to Bid, Information for Bidders, Bid Form, Contract, Bonds, Notice of Award, Notice to Proceed, Change Orders, Drawings, Certificate of Substantial Completion, Specifications, Addenda, these General Conditions, Attachments and Federal Requirements and Contract Provisions when appropriate.
- 1.8 Contract Price - The total monies payable to the Contractor under the terms and Conditions of the Contract Documents.
- 1.9 Contract Specifications Book - A set of documents issued by the Owner for the Project which includes the Invitation to Bid, Information for Bidders, Bid Bond, Bid Form, General Conditions, Technical Provisions and other forms and Attachments.
- 1.10 Contract Time - The specific date or the number of days stated in the Bid Form for the completion of the Work.
- 1.11 Contracting Officer - The authorized agent of the Owner who is administratively responsible for executing the Contract and performing other Work as designated herein, including the duly authorized representative of the Contracting Officer.
- 1.12 Contractor - The person, firm or corporation with whom the Owner has executed the Contract.
- 1.13 Day - A calendar day of 24 hours lasting from midnight one day to midnight the next day.
- 1.14 Drawings - The part of the Contract Documents which show the characteristics and scope of the Work to be performed and which have been prepared for the Owner. The term is used interchangeably with the word "Plans" and includes standard details and drawings bound in the Attachments section.

- 1.15 Engineer – Clark | Azar Associates, 20440 Century Blvd, Suite 220 Germantown MD 20874 (240) 912-3492. **Contact: John Strong, jstrong@clarkazar.com.**
- 1.16 Field Order - A written order issued by the Engineer to the Contractor during construction effecting a change in the Work not involving an adjustment in the Contract Price or an extension of the Contract Time. Also a directive to conform to the terms of the Contract. See Article 13.
- 1.17 Notice of Award - The written notice of the acceptance of the Bid from the Owner to the successful Bidder.
- 1.18 Notice to Proceed - Written communication issued by the Engineer to the Contractor authorizing him to proceed with the work and establishing the dates of commencement and completion of the Work.
- 1.19 Owner - Town of Poolesville.
- 1.20 Owner’s Representative - The authorized representative of the Owner assigned to observe any or all portions of the Work or Materials.
- 1.21 Project - The undertaking to be performed as provided in the Contract Documents.
- 1.22 Shop Drawings - All drawings, diagrams, illustrations, brochures, schedules and other data which are prepared by the Contractor, a Sub-contractor, manufacturer, supplier or distributor, which illustrate how specific portions of the Work shall be fabricated or installed.
- 1.23 Specifications - Invitation to Bid, Information for Bidders, Technical Provisions, and Bid Form.
- 1.24 Standard Details - Details showing standard products, methods and materials for use on this Contract, found in the Attachments Section.
- 1.25 Sub-contractor - An individual, firm or corporation having a direct contract with the Contractor or with any other sub-contractor for the performance of a part of the Work at the site. Sub-contractor shall not mean supplier.
- 1.26 Substantial Completion - That date as certified by the Engineer when the construction of the Project or a specified part thereof is sufficiently completed in accordance with the Contract Documents so that the Project or specified part can be utilized for the purposes for which it is intended.
- 1.27 Supplier - Any person or organization who supplies materials or equipment for the Work (including that fabricated to a special design) but who does not perform labor at the site. Used interchangeably with Vendor.
- 1.28 Work - Any and all obligations, duties and responsibilities necessary to the successful completion of the project assigned to or undertaken by the Contractor under the contract documents, labor, materials, equipment and other incidentals and the furnishing thereof.
- 1.29 Written Notice - Any notice to any party of the Contract relative to any part of the Contract in writing and considered delivered and the service thereof completed when posted by mail to the said party at his last given address, or delivered in person to said party or his authorized representative of the Project.

Article 2. ADDITIONAL INSTRUCTIONS AND DETAIL DRAWINGS

- 2.1 The Contractor may be furnished additional instructions and detail drawings by the Engineer as necessary to carry out the work required by the Contract Documents.
- 2.2 The additional drawings and instructions thus supplied will become a part of the Contract Documents. The Contractor shall carry out the Work in accordance with the additional detail drawings and instructions.

Article 3. SCHEDULES, REPORTS AND RECORDS

- 3.1 The Contractor shall submit to the Engineer, such schedule of quantities and costs, construction progress schedules, payrolls, breakdown of lump sum items, reports, estimates, records and other data where applicable, as are required by the Contract Documents.

Article 4. CONTRACT DOCUMENTS

- 4.1 The intent of the Contract Documents is that the Contractor shall furnish all labor, materials, tools, equipment and transportation necessary for the proper execution of the Work in accordance with the Contract Documents and all incidental work necessary to complete the Project in an acceptable manner, ready for use, and operation by the Owner.
- 4.2 In resolving conflicts, errors and discrepancies within the Contract Documents, the Documents shall be given precedence in the following order:

- Federal Requirements and Contract Provisions
- Change Orders and Field Orders
- Addenda
- General Conditions
- Specifications
- Drawings
- Standard Details

Within the Specifications, the Documents shall be given precedence in the following order:

- Information for Bidders
- Bid Form
- Invitation to Bid
- Technical Provisions

Division 1, General Requirements governs the execution of all Sections of the Specifications from Division 2 through Division 16. Anything mentioned in the Specifications and not shown on the Drawings or shown on the Drawings and not mentioned in the Specifications shall be of like effect as if shown or mentioned in both. Figure dimensions on Drawings shall govern over scale-dimensions and detailed Drawings shall govern over general Drawings.

- 4.3 Any discrepancies found between the Drawings and Specifications or any inconsistencies or ambiguities in the Drawings or Specifications shall be immediately reported to the Engineer in writing, who will promptly correct such inconsistencies or ambiguities in writing. Work done by the Contractor after his discovery of such discrepancies, inconsistencies or ambiguities prior to corrections directed by the engineer shall be done at the Contractor's risk.

Article 5. SHOP DRAWINGS

- 5.1 The Contractor shall provide Shop Drawings as may be necessary for the prosecution of the Work as required by the Contract Documents. The Contractor shall certify that the Shop Drawings comply with the approved Plans and Technical Specifications. Contractor shall also provide a schedule and log for all submittals.

Article 6. MATERIALS, SERVICES AND FACILITIES

- 6.1 It is understood that except as otherwise specifically stated in the Contract Documents, the Contractor shall provide and pay for all materials, labor, tools, equipment, light, power, transportation, supervision, temporary construction of any nature, and all other services and facilities of any nature whatsoever necessary to execute, complete and deliver the Work within the specified time.
- 6.2 Materials and equipment shall be so stored as to insure the preservation of their quality and fitness for the work. Stored materials and equipment to be incorporated in the Work shall be located so as to facilitate prompt inspection. Provide temporary fence as per Section 01800.
- 6.3 Manufactured articles, materials and equipment shall be new and shall be stored, applied, installed, connected, erected, used, cleaned and conditioned as directed by the manufacturer, and as approved by the Engineer. Mechanical and electrical equipment delivered to the job site shall be stored under roof or other approved covering, on pedestals above the ground. All enclosures for equipment shall be weatherproof. Any motors, which are not totally enclosed, that are involved in the work, shall be stored in a heated area with a minimum temperature of 50°F. All valves shall be stored under roof on wood pedestals above ground. The Contractor shall follow all written instructions and recommendations of the manufacturer and all requirements of the Engineer in oiling, protection and maintenance of equipment during storage.
- 6.4 Materials, supplies and equipment shall be in accordance with samples, shop drawings and catalog cuts submitted by the Contractor and approved by the Engineer.
- 6.5 Materials, supplies or equipment to be incorporated into the Work shall be new and shall not be purchased by the Contractor or the Sub-contractor subject to a chattel mortgage or under a conditional sale contract or other agreement by which an interest is retained by the seller.
- 6.6 All Work included in this Contract shall be performed in a skillful and workmanlike manner. The Contractor shall employ no plant, equipment, materials, methods or persons to which the Engineer objects, and shall remove no plant, equipment or other facilities from the site of the work without permission of the Engineer. The Contractor's failure to comply with these requirements will constitute a Breach of Contract and as such may result in a dismissal of the Contractor by the Owner.

Article 7. OBSERVATION AND TESTING

- 7.1 All materials and equipment used in the construction of the Project shall be subject to adequate observation and testing in accordance with generally accepted standards as required and defined in the Contract Documents.
- 7.2 If the Contract Documents, laws, ordinances, rules, regulations or orders of any public authority having jurisdiction require any work to specifically be observed, reviewed, tested, or approved by someone other than the Contractor, the Contractor shall give the Engineer three working days' notice of readiness. The Contractor shall then furnish the Engineer the required certificates of observation, testing or approval.

- 7.3 Observation, tests or approvals by the Engineer or others will not relieve the Contractor from his obligations to perform the Work in accordance with the requirements of the Contract Documents.
- 7.4 The Engineer and his representatives will, at all times, have access to the Work. In addition, authorized representatives of the Owner or agents of any participating Federal, State or local agency shall be permitted from time to time, as in their sole discretion they may deem necessary, to observe and review all work, materials, payrolls, records of personnel, invoices of materials and other relevant data and records. All such records shall remain available and accessible during performance of the Contract and until three years from the date of Final Payment, or, in case of dispute, for a period of three years after resolution of said dispute which ever is later. The Contractor shall provide proper facilities for such access and observation of the work and for any testing thereof.
- 7.5 If any Work is buried or covered without the approval of the Engineer or contrary to requirements elsewhere in the Contract Documents, it shall, if requested by the Engineer, be uncovered for his observation and recovered at the Contractor's expense.
- 7.6 If the Engineer considers it necessary or advisable that approved covered Work be reviewed or tested by others, the Contractor, at the Engineer's request, shall uncover, expose or otherwise make that portion of the work available for observation, review or testing as the Engineer may require by furnishing all necessary labor, materials, tools and equipment. If it is found that such Work is defective, the Contractor shall bear all the expenses of such uncovering, exposure, observation, review and testing and of satisfactory reconstruction. If, however, such Work is not found to be defective, the Contractor will be allowed an increase in the Contract Price or an extension of the Contract Time or both, directly attributable to such uncovering, exposure, observation, review, testing and reconstruction and an appropriate Change Order will be issued.

Article 8. SUBSTITUTIONS

- 8.1 Substitutions will be allowed within the parameters set forth elsewhere in the Contract Documents. See Section 01700.

Article 9. PATENTS

- 9.1 The Contractor shall pay all applicable royalties and license fees. He shall defend all suits or claims for infringement of any patent rights and save the Owner harmless from loss on account thereof, except that the Owner will be responsible for any such loss when a particular process, design or the product of a particular manufacturer or manufacturers as specified is an infringement of a patent. The Contractor shall be responsible for such loss unless he promptly gives such information to the Engineer.

Article 10. SURVEYS, PERMITS, REGULATIONS

- 10.1 Unless otherwise specified, the Engineer will furnish all control points (horizontal and vertical) for locating the principal component parts of the Work together with suitable number of bench marks adjacent to the Work as shown in the Contract Documents. See Section 01000.
- 10.2 Permits and licenses of a temporary nature necessary for the prosecution of the Work, such as plumbing and electrical permits, shall be secured and paid for by the Contractor unless otherwise stated in the Contract Documents. Permits, licenses and easements for permanent structures or permanent changes in existing facilities shall be secured and paid for by the Owner unless otherwise specified.

- 10.3 The Contractor shall give all notices and comply with all permits, laws, ordinances, rules and regulations bearing on the conduct of the Work as drawn and specified. If the Contractor observes that the Contract Documents are at a variance therewith, he shall promptly notify the Engineer in writing and any necessary changes shall be adjusted as provided in Article 13 Changes in the Work.
- 10.4 If any permit, license, certificate, shall expire, be revoked, terminated or suspended as a result of any action on the part of the Contractor, he shall not be entitled to any additional compensation, neither will he be entitled to an extension of the completion date.
- 10.5 Permits obtained by the Owner will be provided to the Contractor at the Pre-Construction Meeting. The Contractor shall comply with all Owner requirements identified in the permits.

Article 11. PROTECTION OF WORK, PROPERTY AND PERSONS

- 11.1 The Contractor shall be responsible for initiating, maintaining and supervising all safety precautions and programs in connection with the Work. He shall take all necessary precautions for the safety of, and shall provide the necessary protection to prevent damage, injury or loss to all employees on the Work and other persons who may be affected thereby, all the work and all materials or equipment to be incorporated therein, whether in storage on or off the site, and other property at the site or adjacent thereto, including trees, shrubs, lawns, walks, pavements, roadways, structures and utilities not designated for removal, relocation or replacement in the course of construction.

In case of suspension of Work for any cause whatsoever, the Contractor shall be responsible for the Project and shall take such precautions as may be necessary to prevent damage to the Work, provide for proper drainage and shall erect any necessary temporary structures, signs, or other facilities at his expense. During such period or suspension of Work, the Contractor shall properly and continuously maintain in acceptable growing condition all living material in newly established plantings, seedings, and sodding furnished under this Contract, and shall take adequate precautions to protect new growth and other important growth against injury.

- 11.2 The Contractor shall comply with all applicable laws, ordinances, rules, regulations and orders or any public body having jurisdiction. He shall erect and maintain, as required by the conditions and progress of the Work, all necessary safeguards for safety and protection. He shall notify owners of adjacent utilities when prosecution of the Work may affect them.
- 11.3 In emergencies affecting the safety of persons or the Work or property at the site or adjacent thereto, the Contractor, shall act, at his discretion, to prevent threatened damage, injury or loss. Any additional compensation or extension of time claimed by the Contractor on account of emergency Work shall be determined as provided in Articles 13 and 14.
- 11.4 When the Owner has been notified by others of emergency situations requiring in the Engineer's opinion, immediate attention and rectification, the Contracting Officer will so notify the Contractor. Should the Contractor not commence Work to rectify the situation within one hour after notification, the Owner may perform the required Work and deduct the costs thereof from monies owed the Contractor.

Article 12. SUPERVISION BY CONTRACTOR

- 12.1 The Contractor shall supervise and direct the Work. He shall be solely responsible for the means, methods, techniques, sequences and procedures of construction. The Contractor shall employ and maintain on the Work a qualified supervisor or superintendent who shall have been designated in writing by the Contractor as the Contractor's representative at the site. The supervisor shall have full authority to act on behalf of the Contractor and all communications given to the supervisor shall

be as binding as if given to the Contractor. The supervisor shall be present on the site at all times as required to perform adequate supervision and coordination of the Work as determined by the Engineer.

Article 13. CHANGES IN THE WORK

- 13.1 Without invalidating the Contract, the Engineer may, at any time or from time to time, by written order, and without notice to the sureties, order additions, deletions or revisions in the Work. These will be authorized by Change Orders. Upon receipt of the Change Order, the Contractor shall promptly and diligently proceed with the Work involved. If any change order causes an increase or decrease in the contract price or scope of the Work, or an extension or shortening of the contract time, an equitable adjustment will be made within the Change Order.

The Engineer may, at the request of the Contractor, issue interpretations, clarifications and other instructions as to be the intent of the Contract Documents, in the form of Field Orders. Upon receipt of such a Field Order containing interpretations, clarifications and other instructions, the Contractor shall proceed with the Work and comply with the Field Order.

- 13.2 The Engineer also may at any time by issuing a Field Order, make changes in the details of the work. The Contractor shall proceed with the performance of any changes in the work so ordered by the Engineer and should the contractor believe that such Field Order entitles him to a change in Contract Price or Time, or both, he shall give the Engineer Written Notice thereof within seven days after the receipt of the Field Order. Thereafter the Contractor shall document the basis for the change in Contract Price or Time within 30 days. Failure to adequately document the basis for the change within the prescribed time shall constitute an abandonment of all entitlement. Failure to proceed shall constitute a breach of contract and shall be cause for the termination of the Contract. Request for a Change Order arising out of a Field Order will not be considered without the attachment thereto of a copy of the referenced Field Order. No claim by the Contractor will be allowed if asserted after Final Payment under this Contract.

Article 14. CHANGES IN CONTRACT PRICE AND TIME

- 14.1 The Contract Price and Time may be changed only by a Change Order. The Change in the Contract Price or the commitment to pay same shall be determined in the manner provided herein, in the following order of precedence:

- a. Unit prices previously approved.
- b. An agreed lump sum.
- c. Force account basis, computed as follows:

1. Labor - For all labor and for foremen in direct charge of the specific operations, the Contractor shall receive the actual rate of wage in effect at the time the force account is performed for each and every hour that said laborer, and foreman are actually engaged in such work. Said agreed rate shall be no higher than that regularly paid the employee. A foreman shall not be used where there are fewer than two laborers employed except with the written consent of the Engineer.

The Contractor shall receive the actual costs paid to or in behalf of workmen by reason of fringe benefits including but not limited to social security contribution, unemployment, excise and payroll taxes, workmen's compensation, health and retirement benefits, sick leave, vacation and holiday pay.

Expense of working after hours, on holidays or on Saturdays and Sundays shall be included to the extent authorized by the Engineer.

Subsistence and travel allowance where required by collective bargaining agreements shall be included.

The charges for labor shall include all classifications through foremen when engaged in the actual and direct performance of the work. They shall not include charges for such overhead personnel as assistant superintendents, office personnel, timekeepers, and maintenance mechanics. An amount equal to 15 percent of the sum of the above items will also be paid the Contractor.

2. Bonds and Insurance. For bonds and insurance premiums or increases thereto necessitated by the force account work, the Contractor shall receive the actual cost to which no percent shall be added. The Contractor shall furnish satisfactory evidence of the rate or rates paid for such bond and insurance.
3. Materials. For materials accepted by the Engineer and used as an integral part of the finished work, the Contractor shall receive the actual cost of such materials delivered on the work, including transportation charges paid by him (exclusive of machinery rentals as hereinafter set forth), to which cost shall be added an amount equal to 15 percent of the sum thereof.

For other materials used in the construction which are not an integral part of the finished work, such as but not limited to sheeting, false work and form lumber, the Contractor shall be reimbursed in the amount agreed upon by the Engineer before such work is begun. The salvage value of such material will be taken into consideration in determining the amount of reimbursement.

4. Equipment for machinery or special equipment other than small tools the use of which has been authorized by the Engineer, the rental rates, including fuel and lubricant but excluding operators, shall be no more than the current rates recommended by the associated Equipment Distributors based on the weekly rental rate converted into hours, assuming a 40 week with eight hour days. Small tools shall be defined as individual pieces of equipment or tools having a new value of \$500 or less.

Equipment on the Work. The rental time to be paid for equipment on the Work shall be the time the equipment is required for the force account work being performed. Moving time, loading, unloading and hauling will not be paid for if the equipment is used at the site of the force account work on other than such force account work.

Equipment not on the Work. For the use of equipment moved in on the Work or used exclusively for work paid for a force account basis, the Contractor will be paid the rental rates hereinbefore specified.

The rental period shall begin at the time the equipment is unloaded at the site of the force account work, shall include each day or fraction thereof that the equipment is at the site of the force account work, excluding Saturdays and Sundays and other legal holidays unless the force account work is performed on such days, and shall terminate at the end of the day on which the Engineer directs the Contractor to

discontinue the use of such equipment. The maximum rental time to be paid per day will not exceed eight hours unless the equipment is in operation for a longer time.

When the Owner is obligated to pay for idle equipment the allowance will be 75 percent of the rate described hereinabove.

5. Compensation

The compensation as set forth above shall be received by the Contractor as payment in full for work done on a force account basis. At the end of each day the Contractor's representative and the Owner's Representative shall compare records of the work performed including classification of all laborers, ordered on a force account basis.

6. Statements. No payment will be made for work performed on a force account basis until the Contractor furnishes the Engineer itemized statements of the cost of such force account work detailed as to the following:

- a. Name, classification, date, daily hours, total hours, rate, and extension for each laborer and foreman.
- b. Designation, dates, daily hours, total hours, rental rate, and extension for each unit of machinery and equipment.
- c. Quantities of materials, prices including transportation cost and extensions.
- d. Cost of bonds and insurance premiums.
- e. Payments of items under Paragraph a. to d. inclusive shall be accompanied by original receipted invoices for materials used and transportation charges. If, however, the materials used in the force account work are not specifically purchased for such work but are taken from the Contractor's stock, then in lieu of the original invoices the statements shall contain or be accompanied by an affidavit of the Contractor which shall certify that such materials were taken from this stock, that the quantity claimed was actually used and that the price and transportation of the material as claimed represent actual cost.

7. Subcontractor's reimbursement for work performed on a force account basis shall be computed in precisely the manner set forth hereinabove. One additional allowance of five percent of the total amount of Sub-contractors' costs will be granted the Contractor regardless of the tier of the Sub-contractor.

14.1.1 If directed, the Contractor shall submit to the Engineer three qualified bids for extra or changed work and materials, if similar work is not being performed at the job site. If directed, the Contractor shall submit daily time charges to the Engineer each day for Change Order work.

14.2 Extensions of time, when granted, will be based upon the effect of delays to the Work as a whole. Extensions of time will not be granted for non-controlling delays to minor included portions of Work unless it can be shown that such delays did, in fact, delay the progress of the Work as a

whole. Extensions of time will not be granted until such time as the Engineer is satisfied they are appropriate and justified.

- 14.3 Where the actual quantity of Work for any pay item varies more than 25 percent above or below the estimated quantity stated in the Contract Documents, an equitable adjustment will be considered upon request of either party. The equitable adjustment shall be based upon any increase or decrease in unit costs due solely to the variation above 125 percent or below 75 percent of the estimated quantity. If the quantity variation is such as to cause an increase in the time necessary for completion, the Engineer shall, upon receipt of a written request for an extension of time, ascertain the facts and make such adjustment for extending the completion date as in his judgment the findings justify in accordance with the provisions of Article 14.2.

Article 15. TIME FOR COMPLETION AND LIQUIDATED DAMAGES

- 15.1 The date of beginning and the time for completion of the Work are essential conditions of the Contract Documents and the Work embraced shall be commenced on the date specified in the Notice to Proceed.
- 15.2 The Contractor shall proceed with the Work at such rate of progress to insure full completion within the Contract Time. It is expressly understood and agreed by and between the Contractor and Owner that the Contract Time for the completion of the Work described herein is a reasonable time, taking into consideration the average climate and economic conditions and other factors prevailing in the locality of the Work.
- 15.3 If the Contractor shall fail to complete the Work within the Contract Time, or extension of time granted by the Engineer, then the Contractor shall pay to the Owner the amount for liquidated damages as specified in the Bid Form for each calendar day that the Contractor shall be in default after the time or date stipulated thereon; and the Owner may deduct the same from monies due from current progress payments or to become due to the Contractor otherwise.
- 15.3.1 Should the Contractor abandon performance of the Work, the Owner shall have the right to complete the Work with its own or other forces, and the liquidated damages provisions set forth herein as well as other provisions of the contract shall remain in effect, and such liquidated damages provisions shall not be construed to be a substitute for damages caused by increased cost of the Work but shall be compensatory only for delay in completion of the Contract.
- 15.3.2 This paragraph does not exclude the recovery of damages by either party under other provisions of the Contract Documents.
- 15.4 The Contractor will not be charged with liquidated damages or any excess cost when the delay in completion of the Work is due to the following and the Contractor has given written notice of such delay to the Engineer within seven days of the occurrence.
- 15.4.1 The unforeseeable causes beyond the control and without the fault or negligence of the Contractor, including but not restricted to acts of God or of the public enemy, acts of the Owner, acts of another Contractor in the performance of a contract with the Owner, fires, floods, epidemics, quarantine restriction, strikes, freight embargoes, and unusually severe weather so documented by the Contractor.
- 15.4.2 To any delays of Sub-contractors occasioned by any of the causes specified in Paragraph 15.4.1 of this article.

- 15.5. No claim by the Contractor for an extension of Contract Time will be allowed based on Work performed under Change Order which increases or decreases the amount due under the Contract Documents unless a time extension is granted pursuant to Article 14.2 as part of the Change Order.

Article 16. CORRECTION OF WORK

- 16.1 The Contractor shall promptly remove from the premises all Work rejected by the Engineer for failure to comply with the Contract Documents whether incorporated in the construction or not, and the Contractor shall promptly replace and re-execute the Work in accordance with the Contract Documents and without expense to the Owner and shall bear the expense of making good all Work of other Contractors destroyed or damaged by such removal or replacement.
- 16.2 All removal and replacement Work shall be done at the Contractor's expense. If the Contractor does not take action to remove such rejected Work within ten days after receipt of written notice, the Engineer may remove such Work and store the materials at the expense of the Contractor.
- 16.3 Unauthorized work - Any Work which may be done or materials ordered by the Contractor prior to receipt of the Notice to Proceed, incorporation of previously rejected Work, Work done contrary to or regardless of the instructions of the Engineer, extra work performed without written authority from the Engineer, Work done beyond the limits shown on the Plans, except as herein specified or any extra Work done without written authority from the Engineer, will be considered as unauthorized and may not be paid for. Work so done may be ordered removed or replaced at the Contractor's expense.

Article 17. CHANGED CONDITIONS

- 17.1 The Contractor shall within seven days, and before such conditions are disturbed, except in the event of an emergency, notify the Engineer by written notice of:
- 17.1.1 Subsurface or latent physical conditions at the site differing materially from those indicated in the Contract Documents, or
- 17.1.2 Unknown physical conditions at the site of an unusual nature, differing materially from those ordinarily encountered and generally recognized as inherent in Work of the character provided for in the Contract Document.
- 17.2 The Engineer will promptly investigate the conditions, and if he finds that such conditions do materially so differ and cause an increase or decrease in the cost of, or in the time required for performance of the Work, an equitable adjustment will be made and the Contract Documents will be modified by a Change Order. Any claim of the Contractor adjustment hereunder shall not be allowed unless he has given the required written notice; provided that the Engineer may, if he determines the facts so justify, consider and adjust any such claims asserted before the date of final payment.

Article 18. PHYSICAL DATA

- 18.1 It is understood that except as otherwise specifically stated in the Contract Drawings, the Owner has not conducted subsurface test borings of the area in which the Work is to be performed.

Article 19. SUSPENSION OF WORK, TERMINATION AND DELAY

- 19.1 The Owner may order the Contractor in writing to suspend, delay, or interrupt all or any part of the Work for such period of time as it may determine to be appropriate for the convenience of the Owner.
- 19.1.1 If the performance of all or any part of the Work is, for an unreasonable period of time, suspended, delayed, or interrupted by his failure to act within a reasonable time, an adjustment shall be made for any increase in the cost of performance of this Contract necessarily caused by such unreasonable suspension, delay or interruption and the Contract modified by Change Order accordingly.
- However, no adjustment shall be made under this clause for any suspension, delay or interruption to the extent: 1) that performance would have been so suspended, delayed or interrupted by any other cause, including the fault or negligence of the Contractor or 2) for which an equitable adjustment is provided for or excluded under any other provision of these Contract Documents.
- 19.1.2 No claim under this article shall be allowed (1) for any costs incurred more than seven days before the Contractor shall have notified the Engineer in writing of the act or failure to act involved (but this requirement shall not apply as to a claim resulting from a suspension order), and (2) unless the claim, in an amount stated, is asserted in writing as soon as practicable after the termination of such suspension, delay or interruption, but not later than the date of final payment under the Contract.
- 19.2 If the Contractor is adjudged bankrupt or insolvent, or if he makes a general assignment for the benefit of his creditors, or if a trustee or receiver is appointed for the Contractor or for any of his property, or if he files a petition to take advantage of any debtor's act, or to reorganize under the bankruptcy or applicable laws, or if he repeatedly fails to supply sufficient skilled workmen or suitable materials or equipment, or if he repeatedly fails to make prompt payments to subcontractors for labor, materials or equipment, or if he refuses or fails to prosecute the Work or any separable part thereof, with such diligence as will insure its completions within the Contract Time, or if he fails to complete said work within said time, or if he disregards laws, ordinances, rules, regulations, directions or orders of any public body having jurisdiction over the Work or if he disregards the authority of the Engineer, or if he otherwise violates any provision of the Contract Documents, then the Owner may, without prejudice to any other right or remedy and after giving the Contractor and his surety a minimum of ten days from delivery of a Written Notice, terminate the services of the Contractor and take possession of the Project and of all materials, equipment, tools, construction equipment and machinery thereon owned by the Contractor, and finish the Work by whatever method it may deem expedient. In such case, the Contractor will not be entitled to receive any future payment until the Work is finished. If the unpaid balance of the Contract Price exceeds the direct and indirect costs of completing the Contract Project, including compensation for additional professional services, such excess will be paid to the Contractor except that the maximum payment will not exceed 10 percent of the original contract. If such costs exceed such unpaid balance, the Contractor shall pay the difference to the Owner. Such costs incurred by the Owner will be determined by the Engineer and incorporated in a Change Order.
- 19.3 Termination of the Contract for any of the above-listed causes, including delinquency of the Contractor during restoration may result in disqualification of the Contractor from bidding on future Owner contracts.
- 19.4 Where the Contractor's services have been so terminated by the Owner, said termination shall not affect any right of the Owner against the Contractor then existing or which may thereafter accrue. Any retention or payment of monies by the Owner due the Contractor will not release the Contractor from compliance with the Contract Documents.

- 19.5 After ten days from delivery of a Written Notice to the Contractor, the Owner may, without cause and without prejudice to any other right or remedy, elect to abandon the Project and terminate the Contract. In such case, the Contractor shall be paid for all Work executed and any expense sustained there from plus reasonable profit for that portion of the Work completed at the date of termination.
- 19.6 If through no act or fault of the Contractor, the Work is suspended for a period of more than 90 days by the Owner or under an order of court or other public authority, or the Engineer fails to respond to any request for payment within 30 days after it is submitted, or the Owner fails to pay the Contractor substantially the sum approved by the Engineer or awarded by arbitrators within 30 days of its approval and presentation, then the Contractor may, after ten days from delivery of a Written Notice to the Engineer, terminate the Contract and recover from the Owner payment for all Work executed and all expenses sustained. In addition and in lieu of terminating the Contract, if the Engineer has failed to respond to a request for payment or if the Owner has failed to make any payment as aforesaid, the Contractor may upon ten days Written Notice to the Engineer stop the work until he has been paid all amounts then due, in which event and upon resumption of the Work, Change Orders will be issued for adjusting the Contract Price, extending the Contract Time, or both to compensate for the costs and delays attributable to the stoppage of the Work.
- 19.7 If the performance of all or any portion of the Work is suspended, delayed or interrupted as a result of a failure of the Engineer to act within the time specified in the Contract Documents, or if no time is specified, within a reasonable time, an extension of the Contract Price, Time or both, shall be made by Change Order to compensate the Contractor for the costs and delays necessarily caused by the failure of the Engineer.

Article 20. USE OF THE PREMISES

- 20.1 The Owner will have the right to enter the premises for the purpose of doing Work not covered by the Contract Documents. This provision shall not be construed as relieving the Contractor of the sole responsibility for the care and protection of the work or the restoration of any damaged Work, except such as may be caused by agents or employees of the Owner.
- 20.2 Prior to the date of Substantial Completion, the Owner, with the concurrence of the Contractor, may use any completed or substantially completed portion of the work. Such use shall not constitute an acceptance of such portions of the Work.

Article 21. SUBSTANTIAL COMPLETION FOR A PORTION OF THE WORK

- 21.1 Whenever the Engineer determines that a portion of the Work is in an apparent acceptable condition and that placing that portion of work into operation will result in a benefit to the Owner, that portion of the Work shall be tested for issuance of a certificate of substantial completion. Upon issuance of the certificate of substantial completion by the Engineer it shall be placed into beneficial operation. The date of substantial completion shall be the effective commencement date for any guarantee applicable as described in Article 31. The Contractor shall be advised of operation and maintenance responsibility commencing with the date of substantial completion.
- 21.2 All written conditions, if any, of the certificate of substantial completion are binding on the Contractor. Failure to comply with such conditions within the time stated therein will be cause for recession of certification of substantial completion and recession of commencement of the

guarantee. Substantial completion and commencement of the guarantee may be reinstated upon reissuance of a certificate of substantial completion by the Engineer as set for above.

Certificate of substantial completion does not relieve the Contractor of his responsibilities under any of the provisions of these Contract Documents unless explicitly noted herein and/or in the written certificate of substantial completion.

Written consent of Surety and endorsement from the insurance carrier or carriers permitting prior occupancy or use of any completed or partially completed portions of the Work by the Owner shall be secured and submitted to the Engineer prior to issuance of certificate of substantial completion.

- 21.3 Until approval of the final estimate for the entire Contract by the Owner, it shall be the Contractor's responsibility to protect and insure all portions of the work in beneficial operation against damages resulting from vandalism, theft, floods, fires and malfunction due to other equipment or Work not yet placed into beneficial operation, unless such damage is the direct result of negligence on the part of Owner personnel or fair wear and tear. Should repairs be required due to any reasons other than the exceptions stated above, they shall be performed at no expense to the Owner, and the guarantee commitment date shall be modified to coincide with the date of re-acceptance in accordance with the provisions set forth herein.
- 21.4 Should the contractor be unable to perform repairs, the Engineer may direct that the necessary repairs be performed by others, and the cost therefore be deducted from monies owed the Contractor. In such a case, the guarantee commitment date shall be modified to coincide with the date of completion of repairs by others.

Article 22. PAYMENTS TO THE CONTRACTOR

- 22.1 At least ten (10) days before each progress payment falls due the Contractor shall submit to the Engineer a partial payment estimate filled out and signed by the Contractor covering the Work performed during the period covered by the partial payment estimate and supported by such data as the Engineer may reasonably require. If payment is requested on the basis of materials and equipment not incorporated in the work, the partial payment estimate shall also be accompanied by such supporting data, satisfactory to the Engineer, as will protect the Owner's interests therein, including applicable insurance. The Contractor shall submit to the Engineer paid invoices for stored materials, if the Contractor includes these costs in his payment requests. See paragraph 22.2. The Engineer will, within ten (10) days after receipt of each partial payment estimate, either indicate in writing his approval of payment and present the partial payment estimate for processing, or return the partial payment estimate to the Contractor indicating in writing his reasons for refusing to approve payment. In the latter case, the Contractor may make the necessary corrections and resubmit the partial payment estimate. The Owner will retain ten percent of the amount of each payment until final completion and acceptance of all Work covered by the Contract Documents. The Owner may at any time, however, after 50 percent of the work has been completed, if it finds that satisfactory progress is being made, may reduce the percent retainage to five percent on the current and remaining estimates. When the work is substantially complete, the retained amount may be further reduced to only that amount necessary to assure completion. On completion and acceptance of a part of the work on which the price is stated separately in the Contract Documents, payment may be made in full, including retained percentages less authorized deductions.
- 22.1.1 Prior to receiving each payment, the Contractor shall certify in writing that he has made payment from proceeds of prior payments and that he will make timely payments from the proceeds of progress and final payment then due him, to his subcontractors and suppliers in accordance with his Contractual arrangements with them.

22.2 The request for payment may also include an allowance for the cost of major materials and equipment not yet incorporated in the Work.

22.2.1 Payment Allowance - When requested in writing by the Contractor and approved by the Engineer, payment allowance will be made for non-perishable major materials and equipment to be incorporated in the work delivered and stockpiled at the Work site or other approved site. Material for which payment has been made, wholly or partially, shall not be removed from the Work site or other approved site.

22.2.2 Payment Allowance for undelivered specially manufactured items or equipment: Payment allowance may be made for undelivered specially manufactured items or equipment, subject to the following stipulations:

The equipment is to be specifically manufactured for this Contract and cannot readily be utilized on nor diverted to another job.

Fabrication period for the equipment of more than six months is anticipated.

The Contractor agrees to submit either acceptance negotiable securities without recourse, conditions or restrictions, or a progress payment bond, or an irrevocable letter of credit in the total amount of the payment allowance to be claimed under these provisions.

Limitations of payment allowances for undelivered items or equipment will be as follows:

A first payment shall be made upon approval by the Engineer of shop drawings in an amount not exceeding ten percent of the item price plus appropriate and allowable higher-tier costs;

Subsequent to the Owner's release or approval for manufacture of said shop drawings, additional payments shall be made not more frequently than monthly thereafter, up to 75 percent of the item price plus appropriate and allowable higher-tier costs. Progress payments shall be proportioned equally so that the final payment of 75 percent will correspond with the date the fabrication is completed and preliminary O&M manuals have been approved. Ancillary on-site Work prior to delivery of such specifically manufactured equipment or items shall be paid for in accordance with provisions of paragraph 22.1.

In no case shall progress payments for such equipment or items be made in an amount greater than 75 percent of the cumulative incurred costs allowable to Contract performance with respect to such equipment or items. Requests for payment allowance under this paragraph shall be accompanied by a certification furnished by the fabricator of the equipment or item stating that the amount of progress payment claimed constitutes the actual cost in no case more than 75 percent of the cumulative incurred cost allowable to the Contract performance, or in the case of the first payment allowance request, a certification that the amount claimed does not exceed 10 percent of the item price quoted by the fabricator.

Payment to the Contractor under this paragraph for materials on hand or on order in no way will be construed as acceptance by the Owner of title to the material. Title shall remain with the Contractor until the Project has been completed and accepted in accordance with provisions herein.

22.3 Upon completion and acceptance of the Work, the Engineer will issue a certificate attached to the final payment request with a copy sent to the Contractor that the Work has been accepted by him

under the conditions of the Contract Documents. The entire balance found to be due the Contractor, including the retained percentages but except such sums as may be lawfully retained by the Owner, will be paid to the Contractor within 30 days of completion and acceptance of the Work.

- 22.4 The Contractor shall furnish to the Owner a Maintenance Bond as described in Article 25 to be in effect for the guarantee period(s) set forth in Article 31.
- 22.5 The Contractor shall indemnify and save the Owner's agents harmless from all claims growing out of the lawful demands of Subcontractors, laborers, workmen, mechanics, materialmen and furnishers of machinery and parts thereof, equipment, tools and all supplies incurred in the furtherance of the performance of the Work. The Contractor shall, at the Engineer's request, furnish satisfactory evidence that all obligations of the nature designated above have been paid, discharged or waived. If the Contractor fails to do so the Owner may, after having notified the Contractor, either pay unpaid bills or withhold from the Contractor's unpaid compensation a sum of money deemed reasonably sufficient to pay any and all such lawful claims until satisfactory evidence is furnished that all liabilities have been fully discharged whereupon payment to the Contractor will be resumed in accordance with the terms of the Contract Documents, but in no event shall the provisions of this sentence be construed to impose any obligations upon the Owner to either the Contractor, his Surety, or any third party. In paying any unpaid bills of the Contractor, any payment so made by the Owner will be considered as a payment made under the Contract Documents by the Owner to the Contractor and the Owner will not be liable to the Contractor for any such payments made in good faith.

Article 23. ACCEPTANCE OF FINAL PAYMENT AS RELEASE

- 23.1 The acceptance by the Contractor of final payment shall be and shall operate as a release to the Owner from all claims and all liability to the Contractor other than claims submitted as specified elsewhere in stated amounts as may be specifically excepted by the Contractor for all things done or furnished in connection with the Work and for every act and neglect of the Owner and others relating to or arising out of this Work.
- 23.2 The Owner shall not be precluded or estopped by any measurement, estimate, or certificate made either before or after the completion and acceptance of the Work and payment therefor, from showing the true amount and character of the Work performed and materials furnished by the Contractor, nor from showing that any such measurement, estimate or certificate is untrue or is incorrectly made, nor from showing that the Work or materials do not in fact conform to the Contract. The Owner shall not be precluded or estopped, not with standing any such measurement, estimate or certificate and payment in accordance therewith, from recovering from the Contractor or his Sureties, or both, such damage as it may sustain by reason of his failure to comply with the terms of the Contract.
- 23.3 Neither the acceptance by the Owner or any representative of the Owner nor any payment for or acceptance of the whole or any part of the Work, nor any extension of time, nor any possession taken by the Owner, shall operate as a waiver of any portion of the Contract or of any power herein reserved, or of any right to recover damages.

The waiver of any breach of the Contract shall not be held to be waiver of any other or subsequent breach.

Article 24. INSURANCE

- 24.1 The Contractor shall purchase and maintain insurance meeting requirements specified herein as will protect him from consequential liability which may arise out of or result from the Contractor's

execution of the Work, whether done personally or by any Sub-contractor or by anyone directly or indirectly employed by any of them or by anyone for whose acts any of them may be liable.

24.1.1 Certificates of insurance shall be filed with the Owner within ten (10) days after receipt of the Notice of Award. These certificates shall contain a provision that policy coverages will not be cancelled, altered or materially changed without 30 days prior written notice provided to the Owner, via registered or certified mail, to the address below:

Commissioners of Poolesville
P.O. Box 158
Poolesville, MD 20837

24.2 The Contractor shall provide the following:

24.2.1 General Public Liability and Property Damages (including vehicles):

Such coverage as will protect the Contractor and Owner from claims for damages because of:

24.2.1.1 Injury to or destruction of tangible property, including loss of use resulting there from;

24.2.1.2 Bodily injury, sickness or disease or death of any person other than those under direct employment of the Contractor;

24.2.1.3 Personal injury sustained by any person as a result of an offense directly or indirectly related to the employment of such person by the Contractor or by any other person;

24.2.1.4 Employee disability and other similar employee benefit acts, including occupational sickness, disease or employee fatalities. Specific insurance coverage requirements include:

24.2.2 Workers' Compensation and Employers' Liability Policy

24.2.2.1 Section A - Statutory limits of state in which work is to be performed.

24.2.2.2 Section B (Employer's Liability) - \$100,000.00 each accident.

24.2.3 Comprehensive General Liability

24.2.3.1 Blanket Contractual Coverage

Bodily Injury - \$500,000.00 each occurrence
Property Damage - \$250,000.00 each occurrence

24.2.3.2 Independent Contractors Coverage

Bodily Injury - \$500,000.00 each occurrence
Property Damage - \$250,000.00 each occurrence

24.2.3.3 Products and Completed Operations Coverage

\$500,000.00 aggregate applicable to Bodily Injury
and
\$250,000.00 each occurrence applicable to Property Damage

24.2.3.4 Personal Injury Coverage (Sections A, B and C)
\$500,000.00 aggregate

Comprehensive General Liability Policy containing an endorsement indicating that the U (Underground) exclusion applicable to a contractor's policy has been deleted, with policy limits accordingly afforded at \$250,000.00 for each occurrence of Property Damage.

24.2.3.5 Deletion of XC Exclusions:

For certain work, the Comprehensive General Liability Policy shall contain an endorsement indicating that the XC (Explosion and Collapse) exclusions applicable to a Contractor's policy have been deleted. Policy limits shall be as specified above for each occurrence of Property Damage. The XC exclusions must be deleted under the following conditions:

24.2.3.5.1 Water Main, Sewer Main, and Storm Drain Construction Contracts:

Whenever explosives of any type are to be used to perform Work as set forth in the contract, and when deemed necessary in the best interests of the Owner.

24.2.3.5.2 Building and Facilities Construction Contracts:

On all contracts under which the contractor will be constructing buildings and/or facilities.

24.2.4 Comprehensive Automobile Liability Applicable to owned, non-owned and hired vehicles

Bodily Injury - \$250,000.00 each person
\$500,00.00 each occurrence.

Property Damage - \$100,000.00 each occurrence.

24.2.5 Excess Liability (Umbrella Form)

24.2.5.1 \$1,000,000.00 with a retention rate not to exceed \$50,000.00 where no underlying coverage exists.

24.3 Supplemental Coverages:

The Contractor shall supply the following additional insurance coverages:

24.3.1 Fire Legal Liability Insurance or Broad Form Property Damage Coverage which contains no water damage exclusion;

Coverage shall be in the amount of the current repair and replacement value of such facility, to include the contents, boilers and machinery contained within such facility.

Article 25. CONTRACT SECURITY

- 25.1 The Contractor shall within 10 days after the date of the Notice of Award furnish the Owner a Performance Bond in penal sum equal to 100 percent of the amount of the Contract Price, and a Payment Bond and a letter of intent to issue Maintenance Bond in penal sums equal to 100 percent of the amount of the Contract Price. Bonds shall be conditioned upon the performance by the Contractor of all undertakings, covenants, terms, conditions and agreement of the Contract Documents, and upon the prompt payment by the Contractor to all persons supplying labor, materials and services in the prosecution of the Work provided by the Contract Documents. The Maintenance Bond shall bind the Contractor as principal and the surety to promptly and properly replace any improper work or materials that may become apparent within a period of 12 months following substantial completion or final acceptance as specified in Article 31.

Such Bonds shall be executed by the Contractor and a corporate bonding company licensed to transact such business in the State of Maryland and named on the current list of "Surety Companies Acceptable on Federal Bonds" as published in the Treasury Department Circular Number 570. The expense of these Bonds shall be borne by the Contractor. If at any time a surety on any such Bond is declared a bankrupt or loses its right to do business in the State of Maryland or is removed from the list of Surety Companies accepted on Federal Bonds, the Contractor shall substitute an acceptable Bond (or Bonds) in such form and sum and signed by such other surety or sureties as may be satisfactory to the Owner. The premiums on such Bond shall be paid by the Contractor. No further payments shall be deemed due nor shall be made until the new surety or sureties shall have furnished an acceptable Bond to the Owner.

- 25.2 Should the Contract Price be increased by 25 percent or more before Final Acceptance, the amount of the Maintenance Bond shall be increased accordingly.

Article 26. ASSIGNMENTS

- 26.1 Neither the Contractor nor the Owner shall sell, transfer, assign or otherwise dispose of the Contract or any portion thereof, or of his right, title or interest therein, or his obligations there under, without written consent of both parties.

Article 27. INDEMNIFICATION

- 27.1 The Contractor shall defend, indemnify and save harmless the Owner from all suits, actions and damages or costs of every name and description to which the Owner may be subject or put by reason of injury to persons (bodily injury, including death, or any personal injury) or property damage as a result of the Work whether caused or alleged to be caused by the negligence, carelessness or willfulness on the part of the contractor, his servants or agents, or on the part of the Owner, its servants or agents, or other cause. Monies due or to become due the Contractor under the Contract as may be considered necessary by the Owner shall be retained by the Owner until such suits or claims for damages shall have been settled or otherwise disposed of or satisfactory evidence to that effect has been furnished to the Owner.

Article 28. SEPARATE CONTRACTS

- 28.1 The Owner reserves the right to let other contracts in connection with this Project. The Contractor shall afford other contractors reasonable opportunity for the introduction and storage of their materials and the execution of their Work and shall properly connect materials and the execution of their Work and shall properly connect and coordinate his Work with theirs. If the proper execution or results of any part of the Contractor's work depends upon the Work of any other contractor, the

Contractor shall inspect and promptly report to the Engineer any defects in such Work that render it unsuitable for such proper execution and results.

- 28.2 The Owner may perform additional Work related to the Project by itself, or it may let other contracts containing provisions similar to these. The Contractor shall afford the other contractors who are parties to such contracts, the Owner, if it is performing the additional Work itself, reasonable opportunity for the introduction and storage of materials and equipment and the execution of Work and shall properly connect and coordinate his Work with theirs.
- 28.3 If the performance of additional Work by other contractors or the Owner is not noted in the Contract Documents prior to the execution of the Contract, Written Notice thereof shall be given to the Contractor prior to starting any such additional Work. If the Contractor believes that the performance of such additional Work by the Owner or others results in additional expense to the Contractor or entitles him to an extension of the Contract Time, he may make a claim there for as provided in Section 13 and 14.

Article 29. SUBCONTRACTING

- 29.1 The Contractor may utilize the services of specialty sub-contractors on those parts of the Work which, under normal contracting practices are performed by specialty sub-contractors, within the parameters set forth herein and in the Information for Bidders.
- 29.2 The Contractor shall not award Work to Sub-contractors in excess of 50 percent of the Contract Price without prior approval of the Contracting Officer.
- 29.3 The Contractor shall be fully responsible to the Owner for the acts and omissions of his sub-contractors and of persons either directly or indirectly employed by them, as he is for the acts and omissions of persons directly employed by him.

The Contractor shall be fully responsible for the coordination of the Work of the trades, sub-contractors and suppliers and their officers, agents and employees.

- 29.4 The Contractor shall cause appropriate provisions to be inserted in all sub-contracts relative to the work to bond sub-contractors to the Contractor by the terms of the Contract Documents insofar as applicable to the Work of sub-contractors and to give the Contractor the same power as regards terminating any subcontract that the Owner may exercise over the Contractor under any provision of the Contract Documents.
- 29.5 Nothing contained in the Contract Documents shall create any contractual arrangement between any sub-contractor and the Owner.

Article 30. ENGINEER'S AND OWNER'S REPRESENTATIVE AUTHORITY

- 30.1 The Engineer will act as the Owner's representative during the construction period. He shall decide questions which may arise as to quality and acceptability of materials furnished and work performed. He will within a reasonable time, make decisions relative to interpretation of the Contract Documents in a fair and unbiased manner. The decisions of the Engineer shall be final and binding upon the parties unless, within 10 days of the Engineer's decision, the Contractor files with the Engineer and the Contracting Officer a written notice of appeal to the Contracting Officer. The Engineer will make visits to the site and determine if the Work is proceeding in accordance with the Contract Documents.

- 30.2 The Contractor will be held strictly to the intent of the Contract Documents in regard to the quality of materials, workmanship and execution of the work. Inspections may be made at the factory or fabrication plant of the source of material supply.
- 30.3 The Engineer will not be responsible for the construction means, controls, techniques, sequences, procedures or construction policy.
- 30.4 Authority and Duties of Owner's Representatives
- 30.4.1 Owner's Representatives are authorized agents of the Owner and shall be authorized to observe all Work done and all material furnished. Such observation may extend to all or any part of Work and to the preparation, fabrication or manufacture of the materials to be used. Owner's Representatives are not authorized to revoke, alter or waive any requirements of the contract, nor are they authorized to approve or accept any portion of the complete Project. They are authorized to call the attention of the Contractor to any failure of the Work or materials to conform to the Contract. They will have the authority to reject materials or suspend the Work until any questions at the issue can be referred to and decided by the Engineer. Owner's Representatives will perform their duties at such times and in such manner as will not unnecessarily impede progress on the Contract.
- 30.4.2 Owner's Representatives will in no case act as foreman or perform other duties for the Contractor, nor interfere with the management of the Work by the latter. Any advice which the Owner's Representatives may give the Contractor shall not be construed as binding the Engineer in any way, or releasing the Contractor from fulfilling all of the terms of the Contract.
- 30.4.3 Where there is disagreement between the Contractor (or his representative superintendent) and the Owner's Representatives, such as refusal by the Contractor to use properly approved materials; or performing Work not in compliance with the Contract Documents; and refusing to suspend Work until problems at issue can be referred to a decision by the Engineer, the Owner's Representatives will immediately direct the Engineer's attention to the issues of disagreement and if the Contractor still refuses to make corrections, comply or suspend Work, the Engineer will prepare and deliver in writing to the Contractor, by mail or otherwise, a written order suspending the work and explaining the reason for such shutdown. As soon as the Owner's Representatives are advised of the delivery of the shutdown order, the Owner's Representatives will immediately leave the site of the Work. Work performed during the Owner's Representatives' absence will not be accepted or paid for and may be required to be removed and disposed of at the Contractor's expense at no additional cost to the Owner.

Article 31. GUARANTEE

- 31.1 The Contractor shall guarantee all materials and equipment furnished and Work performed for a period of one year from the date of Final Contract Acceptance. The Contractor warrants and guarantees that the completed Work is free from all defects due to faulty materials, equipment and workmanship, as further described in Section 01000, and the Contractor shall promptly make such corrections as may be necessary by reason of such defects including the repairs of any damage to other parts of the work resulting from such defects. The Owner will give notice of observed defects with reasonable promptness. In the event that the Contractor should fail to make such repairs, adjustments or other Work that may be made necessary by such defects, the Owner may do so and charge the Contractor the cost thereby incurred.

Article 32. CLAIMS, DISPUTES AND ARBITRATION

32.1 Any claim, dispute or other matters in question between the Contractor and the Owner arising under the terms and provisions of this Contract, including without limitation a claim for breach of contract, shall be referred initially to the Engineer for decision, within the time period established by other applicable provisions of these General Conditions, or if non-established, within 30 days of the event giving rise to the claim, dispute or other matter. Thereafter, the Contractor shall document his position on the claim, dispute or other matter within 30 days by filing with the Engineer a written presentation setting forth in detail the Contractor's position and entitlement to relief. Failure to adequately document a claim, dispute or other matter in a timely manner shall constitute an abandonment of the claim, dispute or other matter initially referred to the Engineer for decision. The Engineer's decision shall be final and binding upon the parties, unless within 10 days of the Engineer's decision, the Contractor files with the Engineer and the Contracting Officer a written notice of appeal to the Contracting Officer. The Contractor will carry on the Work and maintain the progress schedule pending the decision of the Engineer and during any appeal proceedings unless otherwise mutually agreed in writing. Any claim or dispute referred to the Contracting Officer involving \$10,000 or more shall be subject to judicial review on the record by the Court of Montgomery County under the B Rules of Chapter 1100 of the Maryland Rules of Procedure.

32.2. Any claim, dispute or other matter regarding the terms of this Contract or performance thereunder that has been referred initially to the Engineer for decision, may be decided by arbitration if the parties mutually agree, or in a court of competent jurisdiction within the State of Maryland. Should both parties agree to arbitration, the decision shall be made either by:

32.2.1 A neutral person or entity selected by or in accordance with a procedure established by the President of the Commissioners of Poolesville; or

32.2.2 In the event that the other party does not accept as neutral a person or entity selected under paragraph 32.2.1 by an arbitration panel composed of the following:

32.2.2.1 One member designated by the President of the Commissioners of Poolesville;

32.2.2.2 One member of designated by the other party to the dispute; and

32.2.2.3 One member to be selected by mutual agreement of the two designated members from lists to be submitted by the parties to the dispute.

Within 30 days of the filing of the notice of appeal to the neutral person, entity or arbitration panel, the Contractor shall file with such person, entity or panel and the Engineer, the written presentation described above amplified and modified as necessary by the written presentation. Failure to adequately document a claim, dispute or other matter in a timely manner shall constitute an abandonment of the appeal and acceptance of the Engineer's decision as final and binding on the parties. Within 20 days of the filing of the Contractor's written presentation, the Engineer shall file with the neutral person, entity or arbitration panel, a written presentation, setting forth in detail the Engineer's position. The neutral person, entity or arbitration panel may convene an informal hearing upon 5 days notice to both parties, or request either party to supply additional written information. The person, entity or panel shall issue a decision in writing within 45 days after receipt of the Contractor's written presentation. The decision shall be final and binding on the parties.

32.3 Subject to the limitations and conditions imposed herein, the terms and provisions of this Contract, including without limitations a claim for breach thereof, are subject to interpretation under the laws

of the State of Maryland, and any dispute arising there under is subject to binding arbitration under the Construction Industry Arbitration Rules of the American Arbitration Association.

- 32.4 A demand for arbitration shall be filed in writing with the other party of the Contract Documents and with the American Arbitration Association, and a copy shall be filed with the Engineer and the Contracting Officer. Demand for arbitration shall in no event be made on any claim, dispute or other matter in question which would be barred by the applicable statute of limitations or by the provisions of this Article. Arbitration proceedings shall be held in Gaithersburg, Maryland, unless otherwise mutually agreed upon.
- 32.5 The Contractor will carry on the Work and maintain the progress schedule during any appeal or arbitration proceedings, unless otherwise mutually agreed in writing.

Article 33. TAXES

- 33.1 The Contractor shall pay all Federal, State and local taxes for materials furnished under this Contract.

Article 34. OFFICIAL NOT TO BENEFIT

- 34.1 No officer or employee of the Owner shall be admitted to any share or part of the Contract or any benefit that may arise there from, and any contract entered into by the Owner in which any officer or employee of the Owner shall be personally interested shall be void, and no payment shall be made thereon by the Owner or any officer thereof; but this provision shall not be construed to extend to the Contract if made with a corporation for its general benefit.

Article 35. BRIBES

- 35.1 A bribe or attempt to bribe any employee or officer of the Owner by the Contractor shall be considered as execution of the Contract in bad faith and shall thus empower the Owner to complete the work and deduct the entire cost thereof from any monies due or to become due the Contractor under the Contract, all set forth in Article 19.

END OF SECTION

SECTION 01330

SUBMITTAL PROCEDURES

PART 1 - GENERAL

1.01 SECTION INCLUDES

- A. Shop drawings
- B. Samples
- C. Submittal List
- D. Record drawings
- E. O & M manuals
- F. Manufacturer's Certificates

1.02 SUBMISSION – GENERAL

- A. Shop Drawings: Defined as detailed drawings, catalog cuts, manufacturer's specifications, etc.
 - 1. Submit to the Town, in minimum of seven complete sets, four to be retained by Engineer; shop drawings to be submitted on all items of material to be permanently included in Work, as listed in each individual specification section.
 - 2. Present shop drawings in clean and thorough manner with a submittal/transmittal cover (found at the end of this Section) indicating the specification section, plan sheet, and/or any other identifiable information.
 - 3. Stamp each submittal with Contractor's certification that he has reviewed, checked, and approved the shop drawings and that they are in conformance with the requirements of the Contract Documents.
 - 4. Submission of shop drawings shall be by the Contractor only; data prepared by sub-Contractors, suppliers, etc., must be submitted through the Contractor.
 - 5. Review of shop drawings by the Engineer shall not release the Contractor from responsibility for deviations from the Contract Documents.
 - 6. Contractor is responsible for verifying field measurements.
 - 7. Identify specific deviations from Contract Documents.
 - 8. Upon receipt of shop drawings, the Engineer will take one of the following actions, as appropriate:
 - a. REVIEWED W/O COMMENT
 - b. REVIEWED AS COMMENTED – R & R COMMENTED ITEMS ONLY

- c. REVIEWED AS COMMENTED – RESUBMITTAL NOT REQUIRED
 - d. REVISE AND RESUBMIT
 - e. REJECTED
- B. Submit samples, when required by the specification section, of sufficient size to clearly illustrate the functional characteristics of the product and full range of color, texture and pattern as appropriate.
- C. Submittal List.
- 1. Prepare and submit, prior to the start of actual construction, a list of all submittals anticipated.
 - 2. List to be an Excel spreadsheet containing, at a minimum, the information shown on the sample list at the end of this Section.
 - 3. List will be maintained by Contractor and submitted as an agenda item at progress meetings.
- D. Record Drawings: Keep an accurate record of all deviations from Contract Documents and enter onto construction drawings any deviations affected; prepare record drawings of any information not shown on construction drawings; turn record drawings over to Engineer at completion of project, and attach copy of any change order affecting work shown.
- E. O & M Manuals
- 1. Submit manufacturer's O & M Manuals in 5 copies to the Town. Manuals to include parts list, troubleshooting guide, maintenance requirements, and a listing of service representatives.
 - 2. Five (5) electronic versions of the final O & M Manual shall be submitted in .pdf format.
- F. Manufacturer's Certificates
- 1. When specified in individual Sections, submit 3 copies of manufacturer's certificate(s) to Engineer for review.
 - 2. Indicate material and equipment conforms to specified requirements.
 - 3. Submit supporting reference data, affidavits, and certifications as appropriate.
 - 4. Certificates may be recent or previous test results on material or product, but must be acceptable to Engineer.

PART 2 – PRODUCTS (Not Used)

PART 3 – EXECUTION (Not Used)

END OF SECTION

SECTION 02100

CLEARING AND GRUBBING

I. GENERAL

A. Description

This section includes clearing and grubbing as required to complete repairs, in accordance with the Contract Documents.

B. Definitions:

1. Clearing is the removal, within the repair areas, of trees, brush, shrubs, down timber, decayed wood, other vegetation, and rubbish as well as the removal of fences and incidental structures.
2. Grubbing is removing from the ground all stumps, roots, stubs, brush, organic materials and debris.

II. MATERIALS - not applicable.

III. EXECUTION

A. General

1. Clear all items specified herein to the limits required and remove cleared and grubbed material from the site. Do not start earthwork operations in the areas where clearing and grubbing is not complete except that stumps and large roots may be removed concurrent with excavation. Comply with erosion and sediment control measures as directed by the Engineer.
2. Clear and grub areas to be excavated and receiving less than three feet of fill and areas upon which structures are to be constructed, and remove imbedded stumps and root mats to a depth of not less than one foot below the subgrade or slope surfaces. Refill depressions made below subgrade or slope surfaces by the removal of stumps or roots with materials suitable for backfill.
3. Do not burn any material.
4. Remove trees and shrubs in such a manner to avoid damage to trees and shrubs designated to remain. Trees felled outside of the immediate trench excavation or other excavation area shall have their stumps cut to ground level unless directed otherwise by the Engineer. Trees felled within the immediate vicinity of the trench or other excavation shall have their stumps removed and disposed of in an authorized permitted disposal site as specified by the Engineer. Protect all other trees and shrubs from defacement, injury and destruction.

B. Protection

1. Protect property pipe, stones and monuments. Replacement, if required, shall be by a registered Land Surveyor, at no cost to the Owner. Certification by the

registered Land Surveyor of the replacement shall be provided to the Engineer.

2. Remove fences, temporarily, where required, and reset in proposed position. Replace damaged facilities in kind at no cost to the Owner.
3. Protect existing improvements and facilities from damage.

C. Topsoil

Strip existing topsoil from areas where excavation or grading is to be performed. Place in well drained stockpiles in locations approved by the Engineer. Reuse stripped topsoil during restoration work.

IV. MEASUREMENT AND PAYMENT

- A. Clearing and grubbing will not be measured for payment individually but the cost thereof will be considered incidental to the Contract.

END OF SECTION

SECTION 02200

EARTHWORK

I. GENERAL

A. Description

This Section includes excavation, fill, backfill, grading and related items for the proposed work and as directed by the Engineer, in accordance with the Contract Documents.

Definitions

1. Fill material is material used for trench backfill.
2. Filled areas are areas which have received fill or backfill placed and compacted as specified herein.
3. Paved areas are areas over which paving exists or is proposed.
4. Borrow is suitable material meeting requirements specified herein excavated off-site due to lack of approved site excavated material.
5. Structural fill is fill placed under subbase for curbs or pavements.

B. Quality Assurance

1. The Contractor shall furnish a guarantee that filled areas will not suffer from ponding or settlement in excess of the following limitations for a period of one year from the date of final acceptance.
 - a. Type I: (Paved areas and areas within five feet of structures) 0.05 feet.
 - b. Type II (all other areas, including residential) 0.10 foot.

Fill material which settles in excess of the above limitations shall be removed and replaced with suitable material at no cost to the Town. Construction, paving, landscaping and other site improvements damaged by settlement, shall be removed and replaced or reworked with suitable material, at no cost to the Town.

2. Observation and Testing

Perform earthwork under continuous observation of the Geotechnical Engineer provided by the Contractor, as directed by the Engineer. The Geotechnical Engineer may make field density tests of the compaction of each layer of fill in accordance with one of the following: ASTM D1556; ASTM D2167; ASTM D2922; or ASTM D2937. Allow time for the Geotechnical Engineer to perform the tests upon completion of each layer of fill in a designated area. The Contractor shall provide equipment to cut out smooth surfaced spot locations designated by the Geotechnical Engineer on which to perform the test. When the tests indicate

that density or moisture content does not meet requirements specified herein, the particular layer or portion thereof, as determined by the Geotechnical Engineer, shall be reworked by rolling or by scarifying, wetting, or drying or removing and replacing soil to the depth required and re-compacting and retesting until the required density has been obtained.

II. MATERIALS

A. Fill Material

1. General Requirements for all Fill Material

- a. All fill material shall be free of refuse and organic matter, frozen material and other objectionable material. Fill shall be classified as satisfactory if it complies with either the American Association of State Highway and Transportation Officials (AASHTO) M145, Soil Classification Groups A-1, A-2-4, A-2-5, and A-3 or ASTM D2487 Soil Classification Groups GW, GC, GP, GM, ML, CL, CL-ML, SM, SW, SC, and SP. The material shall have moisture content within ± 2 percentage points of the optimum (ASTM D-698), and the plasticity index shall be less than 20. Materials used shall have a minimum dry density of not less than 100 pounds per cubic foot.
- b. Excavated materials meeting these requirements and the requirements stipulated below for the appropriate type of placement shall be used when approved by the Engineer. Otherwise the Contractor shall excavate, haul and place material from other approved sources off site.
- c. Unsatisfactory soil materials are defined as those complying with either AASHTO M145, Classification Groups A-2-6, A-2-7, A-4, A-5, A-6, A-7, or ASTM D2487 Soil Classification Groups MH, CH, OL, OH, and PT.

2. Trench Backfill

- a. Fill material directly surrounding the pipe shall be gravel bedding and shall meet requirements of ASTM C33, Gradation 57, per Figure 3.
- b. Fill material for trenches in Type II areas shall meet the requirements set forth in item 1.a. above. In addition, trench backfill up to three feet over the pipe shall contain no rock or gravel larger than three inches. From three feet over the pipe to 4-inches from the surface, rocks up to 12 inches in their greatest dimension may be used as long as they are contained in a sufficient matrix of soil to avoid point-to-point rock contact. The top 4-inches shall consist of topsoil, as specified in item II.B. of this Section.
- c. Fill material for trenches in Type I (paved) areas shall conform to requirements for fill material described in item 2.a. above up to 12-inches above the top of the pipe. From 12-inches above the top of the pipe to 12-inches below the asphalt pavement base course, fill material shall be MSHA Graded Aggregate Subbase (GASB), compacted to 95% of the maximum dry density at optimum moisture content. From 12-inches

below the asphalt pavement base course to the asphalt pavement base course, fill material shall be MSHA Graded Aggregate Subbase (GASB), compacted to 100% of the maximum dry density at optimum moisture content.

- d. Borrow Trench Backfill, replacement for unsuitable material, shall meet material requirements set forth in items 2.a., 2.b., and 2.c. above, for the appropriate areas.

B. Topsoil

- 1. Topsoil shall consist of fertile, natural surface agricultural soil capable of sustaining vigorous plant growth. It shall contain not less than one and a half percent organic matter as determined by MSHA Standard Method of Test and shall have a pH value of not less than 6.5.
- 2. Topsoil shall be free of stones larger than one (1) inch, roots, rubbish and other objectionable materials such as Bermuda grass, poison ivy and kindred roots and any material harmful to plant growth. Topsoil shall provide sufficient pore space to permit adequate root penetration.
- 3. Topsoil shall meet the analysis of sand, silt and clay when determined in accordance with AASHTO M146 with the following exceptions:

Percent passing by Weight

	<u>Minimum</u>	<u>Maximum</u>
Sand	20	75
Silt	10	60
Clay	5	30

- 4. Topsoil available on the site which meets the above specified requirements may be utilized.

C. Sheeting and Shoring

Sheeting, shoring and bracing materials shall be timber or steel, designed as required to retain the earth around structures, prevent cave-in and settlements, and to fulfill all safety requirements.

- 1. Timber shall be structural grade with minimum working stress of 1,100 psi.
- 2. Steel sheet piling shall conform to requirements of ASTM A328, continuous interlocking type.

III. EXECUTION

A. Excavation

1. General

All material excavated shall be non-classified whether or not indicated. Excavation shall be carried out to the lines and grades required for repairs.

2. Test Pit Excavation

Test pit excavation shall be performed with extreme caution and in such a manner that no damage occurs to the facility being test pitted.

3. Rock Excavation

a. Contractor shall be required to excavate rock should it be encountered while excavating; blasting is not allowed. All rock removal must be approved by the Engineer prior to performing the work.

4. Removal of Unsuitable Material

Where material not meeting the requirements of fill material or deemed unsuitable by the Engineer is encountered either contiguous to or within the proposed limits of excavation required, the Engineer may direct its removal. Depth of removal will be determined by the Engineer. Unsuitable material shall be disposed of off-site by the Contractor, and replaced with materials meeting requirements of Section II.A.

5. Unauthorized Excavation

a. Unauthorized excavation consists of materials beyond indicated subgrade elevations or dimensions without specific direction of Engineer. Unauthorized excavation, as well as remedial work directed by the Engineer, shall be at the Contractor's expense.

b. Under footer and slab bases, fill unauthorized excavation using structural fill by extending the indicated bottom elevation of the footings or base to the excavation bottom, without altering required top elevation. Concrete fill may be used to bring elevations to proper position when acceptable to Engineer.

c. Elsewhere, backfill and compact unauthorized excavations as specified for authorized excavations of same classification, unless otherwise directed by Engineer

6. Sheeting, Shoring and Bracing

a. Sheeting, shoring and bracing shall be placed so as not to interfere with the construction work and shall be entirely independent of all footings and structures.

- b. Remove sheeting, shoring, bracing and all wood forms unless otherwise directed by the Engineer in writing concurrently with backfilling operations in a manner that precludes settlement of the backfill excavation.
- c. Place and remove sheeting and shoring as required to assure safe working conditions and prevent accidents and cave-ins.

7. Trench Excavation with Utilities

- a. Excavate trenches to the width and depth as indicated. Provide uniform and continuous bearing and support for pipe or structure on gravel bedding. Remove rock, when encountered, to a minimum depth of six inches below the pipe, and the same depth below the bell. If the external shape of the trench cannot be preserved or the trench varies from the shape of the structures, the space between the desired trench dimensions and the bottom of the excavation as made, shall be filled with gravel backfill as specified herein before allowing for placement of granular bedding where specified. Material deemed unsuitable by the Engineer in the bottom of the trench shall be removed and replaced with gravel backfill. Depth and width of removal shall be as directed by the Engineer. Perform excavation in the immediate vicinity of adjacent and contiguous facilities by means that will not damage the facility. Damage caused to existing facilities by the Contractor's operations shall be repaired at no expense to the Town.

- b. Trench excavations shall be to the widths shown on Contract Drawings. The Engineer may require backfilling and subsequent re-excavation of trenches left open an unreasonable amount of time in advance of laying of pipe, at no expense to the Owner.

Trenches left open overnight, or during periods when the Contractor's forces are not present shall be so protected or enclosed and marked as to cause no danger to the public or others. Steel plating adequate to carry traffic loads and properly anchored.

- c. Sides of trenches in improved public ways and adjacent to other structures shall be practically plumb. Where permitted by the Engineer, sides of trenches in other areas may be sloped from a point one foot above the top of the pipe to grade. Such slopes shall be at no additional cost to the Owner. Slopes shall be such as will not allow displacement of material or danger to personnel. Bell holes shall be excavated in the bottoms of trenches wherever necessary to permit the proper making of joints.

- d. Trench Sheeting

- (1) Trench sheeting shall conform to requirements specified hereinbefore and the following:
- (2) Where sheeting is used, the trench width as shown on the Standard Details shall be applied between the interior faces of the sheeting as driven.

- (3) Remove sheeting as backfilling progresses. Compact contiguous areas concurrent with removal of sheeting. Leave sheeting in place only when so directed by the Engineer in writing. Trim such sheeting to a minimum of two (2) feet below grade.

B. Backfill and Fill Operations

1. General

- a. Excavations shall be backfilled with soil material excavated therefrom, except in Type I (paved) areas as specified in paragraph II.A.2.c. above, provided this material meets requirements of fill material herein and is approved for use by the Engineer.
- b. Backfill around a structure or pipe shall be brought up evenly on all sides so that no unbalanced pressure will be imposed on the structure or pipe.
- c. Do not place, spread or compact fill material while it is frozen or thawing or place upon frozen or thawing ground or during unfavorable weather conditions. When the Work is interrupted by rain, fill operations shall not be resumed until field tests indicate that the moisture content and density of the fill are within the limits specified. A compacted layer which has been frozen shall be reworked and re-compacted after thawing before the next layer is placed thereon.
- d. Thoroughly mix each lift before compaction to assure uniform distribution of water content. Distribute rocks of permissible sizes through the fill material.

2. Preparation

- a. Before depositing fills, remove all vegetative matter, mud, muck and otherwise unsuitable soils from the surfaces upon which fill materials are to be placed and fill irregularities and cavities.
- b. Completely fill boring bores and test pit excavations within the limits of excavation with sand, lean concrete or crushed stone up to the level of the proposed subgrade, as directed by the Engineer.
- c. When subgrade or existing ground surface to receive fill has a density less than that required to fill, break up ground surface to depth required, pulverize, moisture-condition or aerate soil and recompact to required density.

3. Placing of General Backfill or Fill

- a. Place fill material in layers to required elevations.
- b. Uniformly moisten or aerate subgrade and each subsequent fill layer before compaction to within 2 percent of optimum moisture content.

Remove and replace, or scarify and air-dry satisfactory soil material that is too wet to compact to specified density.

- c. Place backfill and fill materials in layers not more than 8 inches in loose depth for material compacted by heavy compaction equipment, and not more than 4 inches in loose depth for material compacted by hand-operated tampers.
 - d. Place backfill and fill materials evenly on all sides of structures to required elevations. Place backfill and fill uniformly along the full length of each structure.
 - e. Compact soil to not less than the following percentages of maximum dry density according to AASHTO T99.
 - 1. Under structures, footings, slabs, curbs, pavements, and concrete pavers, compact the top 12 inches below subgrade and each layer of backfill or fill material at 95 percent maximum dry density.
 - 2. Under pathways and sidewalks, compact the top 6 inches below subgrade and each layer of backfill or fill material at 95 percent maximum dry density.
 - 3. Under lawn or unpaved areas, compact the top 6 inches below subgrade and each layer of backfill or fill material at 90 percent maximum dry density.
4. Placing Trench Backfill
- a. Type I areas include all areas extending 5 feet beyond the limits of pavement.
 - b. Compact the surface upon which backfill is to be placed to the density specified hereinafter for the compaction of backfill.
 - c. Place granular bedding in accordance with the WSSC Standard Details and MCDPW&T Standards and Specifications.
 - d. In Type I areas under paving and within public rights of way, complete backfill in not more than six-inch loose lifts and compact to 95 percent density as per AASHTO T99 at a moisture content that is within the range where the density can be obtained. Prior to commencing compaction, fills shall be brought to specified water content by either aerating the material if it is too wet, or spraying the material with water if it is too dry.
 - e. In Type II areas complete backfill in not more than 12-inch lifts and compact to 90 percent density as per AASHTO T99 at a moisture content that is within the range where the density can be obtained. Prior to commencing compaction, fills shall be brought to specified water content by either aerating the material if it is too wet, or spraying the material with water if it is too dry.
 - f. When gravel borrow trench backfill material meeting requirements

specified elsewhere herein is utilized, lift height requirements will be determined in the field based on test sections and tests prescribed and observed by the Engineer and based on type of compaction equipment. Backhoe buckets will be permitted for gravel consolidation only.

- g. Utilize such compaction equipment as will not damage the pipe and pipe joints. Pipe and pipe joints damaged by the Contractor's operations shall be removed and replaced at no cost to the Town. Compaction directly adjacent to manhole structures shall be with mechanical tamper.
- h. Do not backfill around pipe, connections or fittings until measurements and locations are completed by the Contractor.

5. Placing Subbase

- a. Under curbs or pavements, place GASB subbase material on prepared subgrades.
 - 1. Compact subbase and base courses at optimum moisture content to required grades, lines, cross sections and thickness to not less than 95 percent of maximum dry density as per AASHTO T99.
 - 2. Shape subbase and base to required crown elevations and cross-slope grades.
 - 3. When thickness of compacted subbase or base course is 6 inches or less, place materials in a single layer.
 - 4. When thickness of compacted subbase or base course exceeds 6 inches, place materials in equal layers, with no layer more than 6 inches thick or less than 3 inches thick when compacted.

C. Finish Grading

- 1. Perform grading operations so that the excavation will be well drained at all times. Maintain drainage ditches and keep them open and free from soil, debris, and leaves until final acceptance of the work. Finish all grading on neat, regular lines in accordance with the criteria set forth hereinafter. Perform grading work in proper sequence with all other associated operations.
- 2. Paved areas; bring finished subgrade to the elevation as required to match proposed cross-section of existing pavement.
- 3. Grassed areas; bring to finished grade elevation with topsoil for uppermost 4 inches.
- 4. Uniformly grade all areas disturbed by the Project, at trench locations, excavated and fill areas and adjacent transition areas so that finished surfaces are at the proposed grade or are approximately at pre-existing grades, adjusted as required to provide positive drainage.

D. Material Storage

Dispose of excess excavated material and unsuitable material off-site. Stockpile approved

topsoil in a location approved by the Engineer/Town. See Section 01900.

E. Dewatering and Drainage

1. If water is encountered in excavation, provide pumps of sufficient capacity to remove the water while the excavations are being made and until utility construction is complete and the excavation has been backfilled. Do not allow sediment laden water to flow into any watercourse or drainageway or overland without first filtering it through an approved desilting device. Use of woven and non-woven filter material will be allowed when approved by the Engineer.
2. Provide all necessary temporary surface drainage and keep the same operating to the satisfaction of the Engineer until permanent drainage or finish grading has been completed. Do not allow damming or pond of water in gutters or storm drains.

F. Restoration of Surface Facilities

The Contractor shall restore and re-stabilize surface features and facilities temporarily removed, damaged, or destroyed during construction to at least the condition existing before construction, in accordance with Section 01900 and other applicable portions of these Specifications.

IV. MEASUREMENT AND PAYMENT

A. Excavation of Unsuitable Material and Replacement with Borrow Backfill Material

Excavation of unsuitable material and replacement with borrow backfill material will be paid for amount of material replaced, as indicated on the Unit Price Schedule. Measurement for payment will be made for the actual quantity of material replaced, as approved by the Engineer. The unit price includes all equipment, materials, preparation and execution of material replacement.

B. Incidental Items

The work of this Section will not be measured for payment but will be considered incidental to the Contract. This shall include but not be limited to the following:

1. Excavation and backfill for trenches.
2. Gravel backfill below subgrade.
3. Excavation of rock.
4. Dewatering and drainage.
5. Finish grading.
6. Preparation of subgrade.
7. Compaction and proof rolling.
8. Drying or wetting of backfill materials.
9. Sheet piling, shoring, and bracing.
10. Additional granular material required with trench sheet piling.
11. Removal of excess material.
12. Gravel base under slabs.
13. Placing structural fill and embankment using suitable materials available on-site.
14. Test pits shown on the Drawings or for the Contractor's convenience.
15. Providing and placement of detectable warning tape.

16. Crushed stone backfill under existing pavement.
17. Geotechnical Engineering testing and evaluation services.
18. Top soil.

END OF SECTION

SECTION 02515

PAVEMENT AND CONCRETE

I. GENERAL

A. Description

This section includes construction of concrete curbs and sidewalks and patching of pavement for the proposed work and as directed by the Engineer, in accordance with the Contract Documents. This section covers the following scope of work:

Patching of pavement.

B. Submittals

1. Submit signed material certifications and/or design mix/gradation certifying that each material item used complies with, or exceeds specified requirements.
2. Submit test results.

C. Quality Assurance

1. The Engineer shall observe all materials upon delivery to site. Any materials determined to be unacceptable by the Engineer shall be removed from the site immediately.
2. All in-place density testing for proper compaction shall be in accordance with the specifications described hereinafter.
3. All work along town roads shall be performed in accordance with the latest Montgomery County Department of Public Works and Transportation (MCDPW&T) and Maryland State Highway Administration (MSHA) "Standard Specifications for Construction and Materials" unless otherwise specified elsewhere. If any discrepancies are found between MCDPW&T and MSHA Standards and Specifications, MCDPW&T Standards and Specifications shall govern.

All work along state roads shall be performed in accordance with the latest Maryland State Highway Administration (MSHA) "Standard Specifications for Construction and Materials" unless otherwise specified elsewhere.

4. Mixing Plant: All bituminous and portland cement concrete mixtures shall conform to MSHA Standard Specifications.
5. All bituminous and portland cement concrete mixtures to be obtained from the same source throughout construction.

II. MATERIALS

A. Portland Cement Concrete

All portland cement concrete and related products shall conform to the MSHA "Standard Specifications for Construction and Materials," Section 902.

B. Bituminous Concrete

All bituminous concrete mixtures shall conform to the MSHA "Standard Specifications for Construction and Materials," Section 904. Base course mixture shall be type BC and surface course mixture shall be type SF. The mixtures shall be produced in a hot mix asphalt plant capable of producing MSHA approved bituminous concrete mixtures. At the completion of the project and before final payment is made, the Contractor shall furnish the Engineer with one complete set of delivery tickets for all bituminous concrete used for construction.

C. Select Borrow

Select borrow material shall be Graded Aggregate-Subbase (GASB), or approved equivalent, conforming to the MSHA Standard Specifications, Section 901.

D. Tack / Prime Coats

Tack or prime coats used as binder between pavement courses shall be diluted emulsified asphalt grade SS-1 or CSS-1, as per MSHA Standard Specifications Section 904.05.

E. Miscellaneous Materials

All other materials for use on this project shall meet the requirements of MSHA "Standard Specifications for Construction and Materials."

III. EXECUTION

A. Concrete Curb and Gutter

1. Contractor shall adjust curb elevations to ensure that all gutters provide positive drainage to inlets with no low points.
2. The Contractor shall provide concrete curb and gutter in accordance with MCDPW&T Standard Detail Nos. MC-100.01 (Type A) and the MSHA "Standard Specifications for Construction and Materials," Section 609.

B. Concrete Sidewalk

1. The Contractor shall provide concrete sidewalk in accordance with MCDPW&T Standard Detail No. MC-110.01 and the MSHA "Standard Specifications for Construction and Materials", Section 610.
2. New sidewalk shall match the grades of adjacent sidewalk. Install ½-inch premolded expansion joints at driveway abutments, around poles and at other permanent structures. Install 3-ply roofing paper at any curb abutments. Where

new sidewalk is to replace and abut existing sidewalk, saw-cut existing sidewalk to provide a clean edge.

C. Bituminous Concrete Pavement Patch

1. Contractor shall receive authorization from the Engineer prior to installing all bituminous concrete pavement. Installation shall be in accordance with the MSHA "Standards and Specifications for Construction and Materials", Section 904. Bituminous mixtures shall not be placed when weather or surface conditions are such that the material cannot be properly handled, transported, furnished or compacted.
2. The surface of the existing paving shall be clean and dry. All excess patch material shall be removed.
3. All asphalt pavement patches shall be constructed in accordance with Contract Drawings. Pavement sections within MSHA right-of-way shall be adjusted or revised as directed by SHA Inspector.
4. Contractor shall use a pavement saw to cut the outline of the patch. The outline of patch shall extend at least 1 foot outside of the distressed area. The outline should be square or rectangular with two of the sides at right angles to the direction of traffic, as approved by the Engineer.
5. Excavate pavement and subgrade, make point repairs, and backfill excavation in accordance with Section 02200 of these Specifications. Make special effort to compact in the corners of the patch.
6. Apply a tack coat to the vertical faces of the excavation.
7. Backfill hole with bituminous concrete base course mixture. Shovel the mixture directly from the truck into the prepared excavation. Place the shovels - full against the edges of the hole first (rather than in the center and then raking to the edges). Bituminous concrete shall be placed in one 4-inch compacted lift. Place an additional 2-inch compacted lift of surface course bituminous concrete on top of base course layer.
8. Spread bituminous concrete mix carefully to avoid segregation of the mixture. Avoid pulling the material from the center of the patch to the edges. If more material is needed at the edge, it should be deposited there, and the excess raked away. The amount of mixture used should be sufficient to ensure that after compaction, the patch surface will be flush with the adjacent pavement.
9. Compact the patch thoroughly using a vibratory plate compactor or roller. Vibratory rollers may not be operated as vibrators on any patches unless the roller is fully contained within the patch.
10. While installing the last lift of bituminous concrete surface course in the patch, overlap the edge of the patch a minimum 1-inch with bituminous concrete. Using a lute, push the bituminous concrete back to the edge of the patch and then lift the lute straight up; only knock off loose aggregate on the top, do not round off the vertical bituminous

concrete. Compact the first 2-inches of the edges of the patch with the roller first. Then proceed to compact the remainder of the patch in one-foot strips

11. The bituminous concrete shall be compacted to an average range of 92% to 97% of its target density as determined by AASHTO test method T-245 Marshall technique, T-209 Theoretical Maximum, or by the control test-strip method.

The installed mat shall be tested for compaction by the nuclear method using a surface moisture densimeter before the bituminous concrete overlay has cooled below 185°F. The amount and interval of in-place tests may vary, but shall not be less than (1) test every 100 linear feet for each day of paving. The Contractor shall be responsible for insuring the surface overlay is tested the same day of installation. Any portion of bituminous concrete pavement that fails to meet the average percent of compaction specified shall be replaced at the Contractor's expense.

12. The variation of the surface in the transverse or longitudinal direction shall not exceed one-quarter of an inch (1/4") as measured with a ten-foot (10') aluminum straight edge. The finished pavement surface must provide positive drainage as intended or as directed by the Engineer to avoid runoff detention. Any areas which detain runoff shall be corrected at the Contractor's expense.
13. No traffic will be permitted on the bituminous concrete overlay until it has set sufficiently to prevent marking. When it is necessary to allow traffic onto freshly placed pavement, the material shall be cooled below 150 degrees F by the use of distributed water immediately following final rolling.

D. Traffic and Lane Markings

1. Replace any disturbed pavement markings in kind.

E. Traffic Controls

Traffic controls shall be in accordance with Section 01800 of these specifications.

F. Miscellaneous

Any incidental items not specifically outlined shall be governed by the latest issue of MSHA Standard Specifications and Details.

IV. METHOD OF MEASUREMENT AND PAYMENT

- A. Work of this Section will not be measured for payment but will be considered incidental to the Contract.

END OF SECTION

SECTION 02660

WATER DISTRIBUTION SYSTEM

I. GENERAL

A. Description

This section includes requirements to construct, test, and chlorinate piping for a water supply and distribution system including fire protection to the limits indicated in accordance with the Contract Documents.

B. Submittals

1. Submit Contractor's Drawings in accordance with Section 01300.

C. Delivery, Storage and Handling

1. All items furnished by the Contractor under this Section may be inspected by the Engineer on the site before installation. Items found to be defective or damaged due to manufacture or shipment, shall be rejected, removed from the contract site and replaced as directed by the Engineer.
2. Loading, unloading, handling, inspection and storage of pipe, fittings, valves, joint accessories and appurtenances shall be in accordance with AWWA C600.

D. Related documents: General Conditions and WSSC Standard Specifications and WSSC Standard Details for Construction.

II. MATERIALS

A. Material Requirements

1. Verification

All items of material furnished by the Contractor under this Section may be reviewed and verified to be in accordance with these Specifications by the Engineer on the Contract site before installation.

2. Pipe and Fittings

a. General

Pipe of the same size and material shall be furnished by the same manufacturer. Each pipe length and fitting shall be clearly marked with the manufacturer's name or trademark.

b. Ductile Iron Pipe and Fittings

- (1) Pipe shall be ductile iron meeting requirements of AWWA C151 with mechanical or push-on joints. Pipe shall be asphaltic coated

outside and cement lined with double thickness and seal coated inside in accordance with AWWA C104. Unless otherwise indicated, the thickness and class of pipe shall be Class 51. Pipe shall be furnished in lengths of 18 to 20 feet and shall include all jointing materials.

Ductile pipe shall be manufactured by:

- (a) American Cast Iron Pipe Co.
 - (b) Atlantic State Cast Iron Pipe Co.
 - (c) Clow Corporation
 - (d) Griffin Pipe Products, Inc.
 - (e) McWane Cast Iron Pipe Co.
 - (f) United States Pipe and Foundry
- (2) Fittings shall be all bell, mechanical joint ductile iron with size, dimensions and tolerances meeting requirements of AWWA C110. Unless otherwise indicated, fittings 3-inch through 12-inch diameter shall have a pressure rating of 250 psi. Mechanical joints shall meet requirements of AWWA C111. Provide all joint accessories, as required, to connect with plain end of push-on joint pipe or cut pipe.

Fittings shall be asphaltic coated outside and cement lined with double thickness and seal coated inside in accordance with AWWA C104.

In addition to the cast markings required in AWWA C110, clearly mark on each fitting the year, month and date cast, and number of lot.

Fittings shall be manufactured by:

- (a) American Cast Iron Pipe Co.
- (b) Clow Corporation
- (c) Griffin Pipe Products Co.
- (d) Russell Pipe and Foundry
- (e) Trinity Valley
- (f) Tyler Pipe Industries, Inc.
- (g) Union Foundry
- (h) United States Pipe and Foundry

c. Copper Pipe and Fittings

Copper pipe shall be seamless, type K and meet requirements of ASTM B88. Fittings shall be copper meeting requirements of ASTM B62 and shall meet requirements of AWWA C800.

- (1) Copper to copper couplings shall be those known as the two part type consisting of a tubing connection, a coupling nut and a friction ring. The copper tub end of the couplings shall be the

flare type for connecting to type K copper service pipe. The opposite end, and all couplings nuts shall be threaded in accordance with AWWA C800.

Copper line couplings shall be one of the following:

- (a) A.Y. McDonald Manufacturing Co. Catalog No. 4756 and 4758 for 1" and ¾" only.
- (b) Ford Meter Box Company, Inc. CS-22 Series, C22-34 for 1" x ¾" only.
- (c) Hays A Division of Romac Industries, Inc. Catalog No. 5610.
- (d) James Jones Co. Catalog No. J-1529.
- (e) Mueller Co. Catalog No. H-15405.

3. Joint Material

- a. Push on and mechanical joints shall meet requirements of AWWA C111.
- b. Mechanical couplings shall be heaviest standard type for each size without pipe stops and as shown on the drawings. Couplings shall be manufactured by Dresser Industries, Inc., Power Seal Pipeline Products Corp., and Rockwell International.

c. Joint Restraining Material

- (1) Retainer glands shall be made of ductile iron and as manufactured by one of the following:
 - (a) American Cast Iron Pipe Company, Model A-90857.
 - (b) Clow Corporation, Model F-1058.
 - (c) Columbus Standard, Regular duty of 4", 6" and 8" only otherwise heavy duty.
 - (d) EBAA Iron, Inc., Megalug series as shown on the drawings.
 - (e) Tyler Pipe Industries, Inc., Model 5-192.
 - (f) Union Foundry, Figure 176.

b. Valve Boxes

Valve boxes shall be as shown on the WSSC Standard Details and shall be manufactured by Bingham and Taylor or Russell Pipe and Foundry.

III. EXECUTION

A. Installation of Water Main

1. Inspection of Delivered Materials

Pipe, fittings, valves and appurtenances delivered to work site may be inspected by the Engineer prior to installation. Non-accepted and damaged materials shall not be installed but shall be removed or repaired, if repairable, as directed by the Engineer.

2. Handling of Pipe and Fittings

a. Ductile and gray iron pipe, fittings, valves and appurtenances shall be handled in accordance with AWWA C600.

b. Foreign matter shall be cleaned and removed from each pipe, fitting and valve before placing in the trench. The interior of the pipe shall be kept clean during installation and thereafter. Open ends of pipes and fittings shall be closed with a watertight seal during periods when work is not proceeding.

3. Excavation

Trench excavation, backfill and test pits shall be as specified in Section 02200. Before excavating, dig test pits to determine size and type of existing pipe to which the proposed pipe will connect and its exact location.

4. Bedding

Provide pipe bedding in accordance with the WSSC Standard Details and Section 02200. Granular bedding is not required for ductile iron pipe 24-inch and smaller diameter and copper house connection pipe. Provide concrete encasement or cradle where indicated. Excavate bell holes at each joint to assemble joint and so entire length of each pipe barrel, fitting and valve is supported on firm bedding.

5. Placement

a. Align pipe so that no shoulder or unevenness results on the inside of the main. Cutting, where required, shall be smooth and at right angles to the pipe axis.

b. Unless otherwise indicated, joint opening for push-on and mechanical joints, horizontal or vertical deflections shall not exceed four degrees for pipe 12-inch and smaller diameter.

6. Buttresses and Harnessed Joints

a. General

Provisions for counteracting all expected thrust due to static and dynamic forces including surge at bends, tees, reducers, valves, fire hydrants and dead-ends shall be made whether or not shown on the drawings.

b. **Harnessed Joints**

- (1) The Contractor shall furnish and install harnessed joints to withstand all expected forces in accordance with the Drawings and WSSC Standard Details.
- (2) Pipe in lengths of 18 feet or more shall be used on both sides of harnessed joints and within the limits as shown on the drawings.
- (3) If the Contractor for his convenience tests the pipeline before backfilling is complete, he shall provide adequate temporary blocking at no cost to the Owner.
- (4) Retainer glands shall be used for harnessing joints on ductile iron pipe where practicable, in accordance with the WSSC Standard Details.

c. **Buttresses**

- (1) Provide buttresses and anchors where indicated on the Drawings and directed by the Engineer in accordance with the WSSC Standard Details.

B. **Joints**

1. **Mechanical Joints**

- a. Assemble the joint in accordance with AWWA C-111 and C-600.

2. **Push-on Joints**

- a. File or grind a bevel on the plain end of field cut pipe lengths to resemble the pipe as manufactured so the plain end will slip into the socket without hindrance or gasket damage. Place an identifying mark on pipe that is not furnished with a depth mark on the plain end to show the depth of the socket.
- b. Assemble joints in accordance with AWWA C600.

C. **Corporation Stop for Chlorination Purposes**

Install one-inch diameter corporation stop and coupling in water mains for chlorination purposes, where directed by the Engineer. Number of corporation stops to be installed will be determined at the preconstruction meeting.

D. **Tapping Sleeve and Valve**

1. Before placing sleeve, clean existing pipe and check pipe outside diameter and ovalness to verify that sleeve will fit and be watertight.
2. Install sleeve and valve. Keep closest edge of sleeve a minimum of nine inches from face of existing joint bell.
3. Air test or test the assembly in accordance with manufacturer's instructions to ensure watertightness in the presence of the Engineer before tapping existing pipe.
4. After saddle installation is complete, bituminous coat saddle assembly as required.

E. Connections to Existing Lines

1. Certain information is shown on the drawings relative to existing pipe and other construction. This information was transferred from existing records and is deemed to be reliable but the Owner does not warrant or guarantee that either the locations, the dimensions or the type of material are exactly as shown.
2. Before installing pipe under this Contract, excavate test pits at all connections to existing water lines. The Engineer will examine the test pits and establish line and grade and determine material required at connections.
3. The Owner will notify consumers and operate all valves necessary to shut down water mains. The Owner will make every reasonable effort to provide a tight shut down but cannot warrant that the mains will be dry and free from all leakage. The Contractor shall pump and provide dewatering as required to make necessary connections to existing water mains. Connections shall be made with the greatest possible speed, working more than eight hours, at nighttime or weekends when directed by the Engineer.

F. Field Testing

1. Hydrostatic tests for water pipes.

Test pipe after completion of backfill operations in lengths as directed by the Engineer.

The Contractor shall provide equipment for and conduct hydrostatic tests with pressures as specified herein. Notify the Engineer when the pipe installation is ready for testing at least five days in advance of test. Set up testing equipment in accordance with WSSC Standard Details. Tests conducted on ductile iron pipe shall meet requirements of AWWA C600.

a. Pressure Test

The pressure to be induced at the low point of the test section for the pressure test is 195 psi.

Fill the length of water main to be tested with water, expelling all air and subject it to the pressure specified above. Maintain this pressure for a

minimum of two hours. Contractor will operate all valves and fire hydrants in the test section during this portion of the test.

b. Leakage Test

Conduct a leakage test concurrently with the pressure test. The pressure to be induced at the high point of the test section for the leakage test is 100 psi. Maintain this pressure for a minimum of 24 hours. Maximum allowable leakage for the water main will be calculated using the following formula.

$$L = \frac{SD\sqrt{P}}{133200}$$

where:

L = maximum allowable leakage, gallons/hour

S = length of pipe in test section, in feet

D = nominal diameter of tested pipe, in inches

P = average test pressure, pounds per square inch which will be computed by averaging the pressure at the low point and the pressure at the high point.

2. Valves shall be operated from the fully closed position to the fully open, and back to the fully closed position after the valve has been installed in the water line. Valve parts shall function smoothly in the manner intended or shall be corrected by the Contractor until satisfactory performance is demonstrated.
3. All visible leakage shall be eliminated. Should test results show displacement, damage or leakage in excess of allowable amount, the Contractor shall repair the displacement and damage and eliminate the leakage. He shall retest until specified conditions are met, to the satisfaction of the Engineer, at no cost to the Owner.

G. Chlorination

1. The Contractor shall introduce chlorine to all new water lines. Use continuous feed method for chlorination as outlined in AWWA C601, Section 7 for disinfecting water mains. The Contractor shall use whatever means are available to ensure that the disinfection procedure minimizes the impact of the disinfectant on the environment, and does not result in a violation of Maryland's water pollution regulations, COMAR 26.08.
2. Continuous feed method
 - a. Proportion mixture of chlorine solution and water so that a minimum of 50 mg/l available chlorine concentration is placed into the main. Fill entire line and appurtenances with this concentration of chlorinated water.
 - b. Retain concentrated chlorinated water in the main for a 24-hour period.

- c. At the end of the 24-hours period, the treated water shall contain no less than 25 mg/l chlorine throughout the main.
- d. Flush out mains at the end of the 24-hour period until the water has a chlorine residual of 0.2 mg/l to 1.0 mg/l.
- E. The Contractor shall take a bacteriological sample after the flushing operation is complete and have it analyzed by the State Certified Testing Laboratory. The sample shall be collected by a person who is Maryland State Certified.
- F. Should the bacteriological test not be satisfactory to the Engineer or the State of Maryland, the Contractor shall rechlorine the main and retesting shall be performed. Rechlorination shall be performed at the Contractor's expense.
- G. The pipelines shall not be placed into service until the analysis is complete and satisfactory to the Engineer and the State of Maryland.

END OF SECTION

SECTION 02930

LAWNS AND GRASSES

I. GENERAL

A. Description

This Section includes requirements for seeding as required for restoration and restabilization of disturbed areas, and as directed by the Engineer, including preparation of materials, providing fertilizer, in accordance with the Contract Documents. All disturbed areas not restored with landscaping or pavement shall be seeded.

B. Reference Documents

A copy of the requirements of Maryland Turf Grass Law and Regulations and Maryland Seed Law and Regulations, available from Maryland Department of Agriculture, Turf and Seed Regulatory, 50 Harry S. Truman Parkway, Annapolis, Maryland 21401, phone (410) 841-5960, shall be obtained and maintained on the work site at all times by the Contractor.

II. MATERIALS

A. Seed

1. Unless otherwise specified herein, seed shall be certified by the Maryland Department of Agriculture and shall conform to requirements of Maryland Seed Law and Regulations.

2. Mix

Tall Fescue

90 - 100 percent certified Adventure, Apache, Arid, Falcon, Finelawn I, or Rebel

Kentucky Bluegrass

0 - 10 percent certified Baron, Bayside, Eclipse, Gnome, Kenblue, or Merit

3. Sow mixture at 195 pounds per acre, or 4.5 pounds per 1,000 square feet between March 1 and May 31 and between August 15 and October 31.

C. Fertilizer

1. Fertilizer shall be uniform in composition, free flowing and delivered to the site fully labeled according to applicable state fertilizer laws and shall bear the name, trade name or trademark and warranty of the producer.

2. The Contractor may submit soil samples to an approved soils testing laboratory for fertilizer recommendations. Recommendations shall be submitted to and approved by the Engineer before implementation.

3. Unless otherwise directed, fertilize at the following rates:

a. Temporary Seeding

Provide 10-20-10 or equivalent at the rate of 600 pounds per acre or 15 pounds per 1,000 square feet.

b. Permanent Seeding

Provide 600 pounds of 0-20-20 per acre with limestone. Immediately prior to seeding, supply 400 pounds of 38-0-0 ureaform and 500 pounds of 10-20-20 or equivalent per acre.

III. EXECUTION

A. Permanent Seeding

1. Harrow, disc, or otherwise loosen subsoil to a depth of four inches.
2. Remove objectionable material such as stones, two inches or larger, clods, brush, roots and trash from the top four inches of soil.
3. Apply fertilizer at the rates specified in Part II, Materials, and thoroughly mix into the top six inches.
4. Immediately prior to seeding apply additional fertilizer at the rates specified in Part II, Materials, and work into top two inches of the soil.
5. Perform harrowing, discing, scarifying and raking on the contour of slopes steeper than 3:1.
6. Moisten seedbed during periods of high temperatures and when directed by the Engineer.
7. Apply seed mixture uniformly with mechanical power driven seeders, mechanical cyclone hand seeders or hydroseeding equipment. Slurry for hydroseeder may contain seed and fertilizer only.

C. Temporary Seeding

1. Loosen top two inches of seedbed.
2. Apply fertilizer at the rates specified in Part II, Materials.
3. Moisten seedbed during periods of high temperature and when directed by the Engineer.
4. Apply seed mixture uniformly with mechanical power drawn seeders, mechanical cyclone hand seeders or hydroseeding equipment. Slurry for hydroseeder may contain seed and fertilizer only.

D. Time Restrictions

1. When permanent seeding is specified or directed, and seeding is not allowed because of time restrictions specified in Part II, Materials, utilize one or more of the following methods to prevent erosion and sedimentation until such time as permanent seeding is allowed:

- a. Apply temporary seeding

E. Maintenance of Seeded Areas

1. Maintain seeded areas until accepted in writing by the Engineer.
2. Water seeded areas as necessary to maintain adequate moisture in the upper four inches of soil and keep mowed to a height of two to three inches. Do not remove more than 1/3 of the grass leaf during initial mowing.
3. Inspect seeded areas for failures and necessary repairs.
4. Provide replacements during the specified planting seasons.

IV. MEASUREMENT AND PAYMENT

- A. Lawns and grass work will not be measured for payment and the costs thereof will be considered incidental to the Contract.

END OF SECTION

BID BOND FORM

Contract No. **100.062**
Date Bond Executed

KNOW ALL PERSONS BY THESE PRESENTS THAT,

(Here insert legal name of the Contractor)

(Here insert the address of the Contractor)

As PRINCIPAL, hereinafter called "Contractor," and

(Here insert the legal name of the Surety)

(Here insert the address of the Surety)

As SURETY, hereinafter called "Surety", are held and firmly bound unto THE TOWN OF POOLESVILLE, a municipal corporation of the State of Maryland, as OBLIGEE, hereinafter called the "COMMISSIONERS", for the use and benefit of claimants as hereinbelow defined, in the penal sum of _____ dollars (\$ _____), for the payment whereof Contractor and Surety bind themselves, their heirs, executors, administrators, successors, and assigns, jointly and severally, firmly by these presents.

WHEREAS, the Contractor herein is herewith submitting his Bid Form for **Contract No. 100.062 Town of Poolesville, Kohlhoss Water Line Replacement**, said Bid Form being made a part hereof to the same extent as if fully set out herein.

NOW, THEREFORE, if the said Bid Form submitted by the Contractor be accepted and Contract be awarded to said Contractor, and if the said Contractor shall execute the proposed Contract and shall furnish the "Performance and Payment Bonds", as required within the Contract Documents within the time established therein, then his obligation shall be void; if the Contractor shall fail to execute the proposed Contract and furnish the "Performance and Payment Bonds," the Surety hereby agrees to pay the Commissioners, the penal sum as liquidated damages.

Signed and sealed this _____ day of _____, A.D., 2024

Contractor (Principal) Name

ATTEST

By _____ SEAL _____

SURETY NAME

(Title) SEAL _____

NOTE: Attach hereto Power of Attorney

AFFIDAVIT OF NON-CONVICTION

I hereby swear or affirm under the penalty for perjury:

(1) That I am the individual Bidder, or a partner in the partnership bidding, or an officer, director or employee of a business entity bidding and have the authority to make this affidavit on behalf of the partnership or business entity; and

(2) That I the signatory have not been convicted under the provisions of Article 27 of the Maryland Annotated Code, of bribery, attempted bribery or conspiracy to bribe and/or during the course of an investigation or other proceeding have not admitted any acts or omissions which could constitute bribery, attempted bribery or conspiracy to bribe under aforementioned Article, or have not been convicted under any other State or Federal Law of bribery, attempted bribery or conspiracy to bribe in connection with any contractor or bid therefore with any State or County agency for the supply of goods or services; and

(3) If the bidder herein is a business entity, that to the best of my knowledge, the bidding business entity or any of its officers, directors or partners or any of its employees directly involved in obtaining contracts with the State or County agencies has not been convicted of bribery, attempted bribery or conspiracy to bribe under the laws of any State or Federal government.

(4) That I have fully informed myself regarding the accuracy of the statements made in this affidavit.

Signed _____

Firm Name _____

Subscribed and sworn to
before me this _____ day of _____, 2024

Notary Public _____

My Commission expires _____, 2024

TO: THE COMMISSIONERS OF POOLESVILLE
P.O. BOX 158
POOLESVILLE, MARYLAND 20837
PROPOSAL FOR CONTRACT NUMBER 100.062
KOHLSHOSS WATER LINE REPLACEMENT

Made this _____ day of _____, 2024 by _____

business address, _____

The bidder declares that the only person, firm or corporation, or persons, firms or corporations, that has or have any interest in this proposal, or in the contract or contracts proposed to be taken, is or are the undersigned; that this proposal is made without any connection or collusion with any person, firm, or corporation making a proposal for the same work; that the attached specifications and form of contract therein referred to, have been carefully examined and are understood; that as careful an examination has been made as is necessary to become informed as to the character and extent of the work required; and that it is proposed and agreed, if the proposal is accepted, to contract with The Commissioners of Poolesville, the form of contract hereto attached, to do the required work in the manner set forth in the specifications.

I/We propose to furnish all labor, equipment, materials and other facilities and things necessary and proper to construct the "**Kohlhoss Avenue Water Line Replacement**" in accordance with the Bid Documents, therefore, at and for the price shown below:

Dollars _____ Cents (\$ _____).

(Bid Alternate) Dollars _____ Cents (\$ _____).

THIS CONTRACT SHALL BE COMPLETED WITHIN 180 CALENDAR DAYS FROM NOTICE TO PROCEED.

If this proposal shall be accepted by the Commissioners and the undersigned shall refuse or neglect ten days after receiving the contract for execution, to execute the same, then said Town may, at its option, determine that the bidder has abandoned the contract, and thereupon the proposal and the acceptance thereof shall be null and void, and the deposit accompanying the proposal shall be forfeited to and become the property of said Town.

Should bidder fail to complete this contract on or before 180 calendar days after receipt of written notification to proceed, bidder further agrees to pay as liquidated damages the sum of \$300.00 for each consecutive calendar day thereafter.

NOTE: The Bidder or bidders must sign here, and the addresses of each must be signed and subscribed to by at least one member. In the case of corporations, the corporate name must be signed by some authorized officer or agent thereof; who shall also subscribe his name and office. If practicable, the seal of the corporation shall be affixed.

BIDDER _____ SIGNATURE _____
BUSINESS ADDRESS _____
_____ TELEPHONE NO. _____

The names and addresses of all members of a firm, or the names, addresses, and titles of every officer of a corporation, as the case may be, must be given here by the member of the firm, or by the officer or agent of the corporation who signs the proposal.

NAME	ADDRESS	TITLE
_____	_____	_____
_____	_____	_____
_____	_____	_____
_____	_____	_____
_____	_____	_____

U.S. Treasury Department Employer's Identification Number:

PRICE SCHEDULE
TOWN OF POOLESVILLE Kohlhoss Water Line Replacement
BASE BID

The Bidder shall include unit prices for the following items of work. The total of all unit price items shall equal the lump sum price indicated on page BF-4 of the proposal form.

<u>Division</u>	<u>Description</u>	<u>Price</u>
1	General Requirements	_____
2	Excavation for Waterline	_____
3	Placement of watermain and pipe Per foot _____	_____
4	Placement of valves and valves Per Valve _____	_____
5	Lateral connections Per Lateral Connection _____	_____
6	Abandonment of existing waterline	_____
7	Appurtenances	_____
8	Pavement Patching	_____
9	Mobilization/Demobilization	_____
TOTAL PRICE _____		
(Shown on Page BF-4)		

CONTRACTOR'S QUALIFICATION STATEMENT

Project: TOWN OF POOLESVILLE KOHLHOSS WATER LINE REPLACEMENT

Contractor: _____

A. Recent Projects

List a minimum of 3 recent projects indicating similar experience to this project.

Project Name	Owner Address & Phone	Description of Work	Contract Values
1.			
2.			
3.			

B. Number of Employees

Provide number of permanent employees on staff by category. Indicate number of employees to be assigned to this project.

Category	Total on Staff	Total This Project	%
Administrative			
Project Managers			
Superintendents			
Foreman			
Equipment Operators			
Carpenters			
Pipe Layers			
Plumbers			
Electricians			
Laborers			
Others			

C. Equipment

List type of equipment owned by Contractor to be used on this project. List rental equipment to be used on this project.

Type of Equipment	Owned	Rental
1.		
2.		
3.		
4.		
5.		
6.		
7.		

D. Subcontractors

List all subcontractors to be utilized on this project.

Company	Trade/Specialty	Percent of Contract Work
1.		
2.		
3.		

E. Suppliers

List a minimum of three suppliers with current accounts.

Supplier Name & Phone	Account Number
1.	
2.	
3.	

F. Maximum Bonding Limit: _____

I hereby affirm that the above information is correct to the best of my knowledge.

Signed: _____

Title: _____

FORM FOR SUBSTITUTIONS FOR SPECIFIED ITEMS

Specified Material	Replacement Material	Estimated Quantity	Total Change In Price
1.			
2.			
3.			
4.			

ACKNOWLEDGEMENT OF ADDENDA

The Commissioners of Poolesville
Contract No. 100.062
Kolhoss Water Line Replacement

The bidder acknowledges below, all addenda received relating to this project.

Acknowledgement of Addenda:

Addendum # _____

Addendum # _____

Addendum # _____

Addendum # _____

Addendum # _____

Addendum # _____

BIDDER: _____

AGREEMENT

THIS AGREEMENT is dated as of the _____ day of _____ in the year 20____ by and between the Town of Poolesville, a municipal corporation of the State of Maryland (hereinafter called OWNER) and _____ (hereinafter called CONTRACTOR).

OWNER and CONTRACTOR, in consideration of the mutual covenants hereinafter set forth, agree as follows:

ARTICLE 1. WORK

CONTRACTOR shall complete all work as specified or indicated in the contract documents for Kohlhoss Water Line Replacement, Contract # 100.062. The work is generally described as follows:

Description of Project:

Replacement and installation of watermain, abandonment of existing water main, connecting replacement water main to the existing waterline laterals, and patching of roadway per plans and specifications.

ARTICLE 2. ENGINEER

The Project has been designed by Clark | Azar Associates, who is hereinafter called ENGINEER and who will assume all duties and responsibilities and will have the rights and authority assigned to ENGINEER in the Contract Documents in connection with completion of the Work in accordance with the Contract Documents.

ARTICLE 3. CONTRACT TIME

- 3.1 The Work shall be fully completed and ready for final payment in accordance with Article 23 of the General Conditions within 180 calendar days after the date when the Contract Time commences to run.
- 3.2 Liquidated Damages. OWNER and CONTRACTOR recognize that time is of the essence of this Agreement and that OWNER will suffer financial loss if the Work is not substantially complete within the time specified in paragraph 3.1 above, plus any extensions thereof allowed in accordance with Article 14 of the General Conditions. They also recognize the delays, expense and difficulties involved in proving in a legal or arbitration proceeding the actual loss suffered by OWNER if the Work is not substantially complete on time. Accordingly, instead of requiring any such proof, OWNER and CONTRACTOR agree that as liquidated damages for delay (but not as a penalty) CONTRACTOR shall pay OWNER three hundred dollars (\$300.00) for each calendar day that expires after the time specified in paragraph 3.1 for completion of the Work.

ARTICLE 4. CONTRACT PRICE

OWNER shall pay CONTRACTOR for performance of the Work in accordance with the Contract Documents in current funds based on the actual measured quantities of Work complete and in place, and the unit prices shown on the CONTRACTOR'S Bid Form, attached as Exhibit A and made a part hereto.

ARTICLE 5. PAYMENT PROCEDURES

CONTRACTOR shall submit monthly Application for Payment in accordance with Article 22 of the General Conditions. Applications for Payment will be processed by ENGINEER as provided in the General Conditions.

- 5.1 Progress Payments. OWNER shall make progress payments on account of the Contract Price on the basis of CONTRACTOR's Applications for Payment as recommended by ENGINEER. All progress payments will be on the basis of the progress of the Work measured by the schedule of values provided for in Article 22 of the General Conditions and in the Bid Form. The OWNER shall make progress payments within 30 days of the date of the ENGINEER's approval.
- 5.2 Final Payment. Upon final completion and acceptance of the work in accordance with the General Conditions, OWNER shall pay the remainder of the Contract Price as recommended by ENGINEER as provided in said General Conditions.

ARTICLE 6. CONTRACTOR'S REPRESENTATIONS

In order to induce OWNER to enter into this Agreement CONTRACTOR makes the following representations:

- 6.1 CONTRACTOR has familiarized himself with the nature and extent of the Contract Documents, Work, locality, and with all local conditions and Federal, State and local laws, ordinances, rules, permits and regulations that in any manner may affect cost, progress or performance of the Work.
- 6.2 CONTRACTOR has made or caused to be made examinations, investigations and tests and studies as he deems necessary for the performance of the Work at the Contract Price, within the Contract Time and in accordance with the other terms and conditions of the Contract Documents; and no additional examinations, investigations, tests, reports, or similar data are or will be required by CONTRACTOR for such purposes.
- 6.3 CONTRACTOR has correlated the results of all such observations, examinations, investigations, tests, reports and data with the terms and conditions of the Contract Documents.

- 6.4 CONTRACTOR has given ENGINEER written notice of all conflicts, errors or discrepancies that he has discovered in the Contract Documents and the written resolution thereof by ENGINEER is acceptable to CONTRACTOR.

ARTICLE 7. CONTRACT DOCUMENTS

The Contract Documents which comprise the entire agreement between OWNER and CONTRACTOR are attached to this Agreement, made a part hereof and consists of the following:

- 7.1 This Agreement
- 7.2 CONTRACTOR'S Bid Form
- 7.3 Notice of Award
- 7.4 General Conditions
- 7.5 Any Modification, including Change Orders, duly delivered after execution of Agreement.
- 7.6 Specifications, bearing the title Contract Specifications and Plans, Kohlhoss Water Line Replacement, Contract # 100.062.

The Contract Documents may only be altered, amended or repealed by a Field Order or a Change Order (as defined in Article 1 of the General Conditions).

ARTICLE 8 INDEPENDENT CONTRACTOR

- 8.1 Terms used in this Agreement which are defined in Article 1 of the General Conditions shall have the meanings indicated in the General Conditions.
- 8.2 No assignment by a party hereto of any rights under or interests in the Contract Documents will be binding on another party hereto without the written consent of the party sought to be bound; and specifically but without limitation, moneys that may become due and moneys that are due may not be assigned without such consent (except to the extent that the effect of this restrict may be limited by law), and unless specifically state to the contrary in any written consent to and assignment no assignment will release or discharge the assignor from any duty or responsibility under the Contract Documents.

ARTICLE 9 INDEMNIFICATION

- 9.1 CONTRACTOR agrees to indemnify and save harmless the OWNER against all liabilities, claims and demands for personal injury or property damage or other expenses suffered or arising out of or caused by any negligent act or omission of CONTRACTOR, its

subcontractors, servants, agents or employees incurred in the performance of this Agreement, and shall secure appropriate personal and property damage insurance for protection of the owner in amounts found to be sufficient by the OWNER as specified in Section 24.2 of the General Conditions.

ARTICLE 10 MISCELLANEOUS

10.1 Terms used in this Agreement which are defined in Article 1 of the General Conditions shall have the meanings indicated in the General Conditions.

10.2 No assignment by a party hereto of any rights under or interests in the Contract Documents will be binding on another party hereto without the written consent of the party sought to be bound; and specifically but without limitation, moneys that may become due and moneys that are due may not be assigned without such consent (except to the extent that the effect of this restrict may be limited by law), and unless specifically state to the contrary in any written consent to and assignment no assignment will release or discharge the assignor from any duty or responsibility under the Contract Documents.

10.3 OWNER and CONTRACTOR each binds himself, his partners, successors, assigns and legal representatives to the other party hereto, his partners, successors, assigns and legal representatives in respect to all covenants, agreements and obligations contained in the Contract Documents.

IN WITNESS WHEREOF, the parties hereto have signed this Agreement in triplicate. One counterpart each has been delivered to OWNER and CONTRACTOR. All portions of the Contract Documents have been signed or identified by OWNER and CONTRACTOR.

This AGREEMENT will be effective on _____, 20__.

OWNER: Town of Poolesville

CONTRACTOR: _____

By: _____

By: _____

Corporate Seal

Attest: _____

Attest: _____

Address for giving Notices

Address for giving Notices

Town of Poolesville
P.O. Box 158
Poolesville, Maryland 20837

License No. _____

Agent for service of process:

PERFORMANCE BOND

KNOW ALL PERSONS BY THESE PRESENTS THAT,

(Here insert legal name of the Contractor)

(Here insert the address of the Contractor)

a _____, hereinafter called PRINCIPAL, and
(Corporation, Partnership, or Individual)

(Here insert the legal name of the Surety)

(Here insert the address of the Surety)

hereinafter called SURETY, are held and firmly bound unto

TOWN OF POOLESVILLE, hereinafter called the OWNER, Box 158, Poolesville, Maryland 20837,

hereinafter called OWNER, in the penal sum of _____

(\$ _____) in lawful money of the United States, for the payment of which sum well and truly to be made, we ourselves, successors, assigns, jointly and severally, firmly by these presents.

THE CONDITION OF THIS OBLIGATION is such that whereas, the PRINCIPAL entered into a certain contract with the OWNER, dated the ___ day of _____, 20__, a copy of which is hereto attached and made a part hereof for the construction of:

Kohlhoss Water line Replacement, Contract # 100.062

Please refer to contract documents for specific information

NOW, THEREFORE, if the PRINCIPAL shall well, truly and faithfully perform its duties, all the undertakings, covenants, terms, conditions, and agreements of said contract during the original term thereof, and any extensions thereof which may be granted by the OWNER, with or without notice to the SURETY, and during the one year guaranty period, and if he shall satisfy all claims and demands incurred under such contract, and shall fully indemnify and save harmless the OWNER from all costs and damages which if may suffer by reason of failure to do so, and shall reimburse and repay the OWNER all outlay and expense which the OWNER may incur in making good any default, then this obligation shall be void; otherwise to remain in full force and effect.

PROVIDED, FURTHER, that the said surety, for value received hereby stipulates and agrees that no change, extension of time, alteration or addition to the terms of the contract or to WORK to be performed thereunder or the SPECIFICATIONS accompanying the same shall in any wise affect its obligation on this BOND, and it does hereby waive notice of any such change, extension of time, alteration or addition to the terms of the contract or to the WORK or to the SPECIFICATIONS.

PROVIDED, FURTHER, that no final settlement between the OWNER and the CONTRACTOR shall abridge the right of any beneficiary hereunder, whose claim may be unsatisfied.

IN WITNESS WHEREOF, this instrument is executed in three (3) counterparts, each one of which shall be deemed an original, this ___ day of _____, 20__.

ATTEST

(Principal) Secretary

Principal _____
By _____

(SEAL)

(Witness as to Principal)

(Address)

(Address)

Surety

ATTEST:

(Surety) Secretary

(SEAL)

Witness as to Surety

By _____
Attorney-in-Fact

(Address)

(Address)

NOTE: Date of BOND must not be prior to date of Contract. If CONTRACTOR is Partnership, all partners should execute BOND.

IMPORTANT: Surety companies executing BONDS must appear on the Treasury Department's most current list (Circular 570 as amended) and be authorized to transact business in the state where the PROJECT is located.

PAYMENT BOND

KNOW ALL PERSONS BY THESE PRESENTS THAT

(Here insert legal name of the Contractor)

(Here insert the address of the Contractor)

a _____, hereinafter called PRINCIPAL,
(Corporation, Partnership or Individual)

and _____
(Here insert the legal name of the Surety)

(Here insert the address of the Surety)

hereinafter called SURETY, are held and firmly bound unto

TOWN OF POOLESVILLE, hereinafter called the OWNER, Box 158, Poolesville, Maryland 20837,

hereinafter called OWNER, in the penal sum of _____

(\$ _____) in lawful money of the United States, for the payment of which sum well and truly to be made, we bind ourselves, successors, and assigns, jointly and severally, firmly by these presents.

THE CONDITION OF THIS OBLIGATION is such that whereas, the PRINCIPAL entered into a certain contract with the OWNER, dated the ____ day of _____, 20__, a copy of which is hereto attached and made a part hereof for the construction of:

Kohlhoss Water Line Replacement, Contract # 100.062

Please refer to contract documents for specific information

NOW, THEREFORE, if the PRINCIPAL shall promptly make payment to all persons, firms, SUBCONTRACTORS, and corporations furnishing materials for or performing labor in the prosecution of the WORK provided for in such contract, and any authorized extension or modification thereof, including all amounts due for materials, lubricants, oil, gasoline, coal and coke, repairs on machinery, equipment and tools, consumed or used in connection with the construction of such WORK, and all insurance premiums on said WORK, and for all labor, performed in such WORK whether by SUBCONTRACTOR or otherwise, then this obligation shall be void; otherwise to remain in full force and effect.

PROVIDED, FURTHER, that the said SURETY for value received hereby stipulates and agrees that no change, extension of time, alteration or addition to the terms of the contract or to the WORK to be performed thereunder or the SPECIFICATIONS accompanying the same shall in any way affect this obligation on this BOND, and it does hereby waiver notice of any such change, extension of time, alteration or addition to the terms of the contract or to the WORK or to the SPECIFICATIONS.

PROVIDED, FURTHER, that no final settlement between the OWNER and the CONTRACTOR shall abridge the right of any beneficiary hereunder, whose claim may be unsatisfied.

IN WITNESS WHEREOF, this instrument is executed in three (3) counterparts, each one of which shall be deemed an original, this _____ day of _____, 20__.

ATTEST:

Principal

(Principal) Secretary

By _____ (s)

(SEAL)

(Address)

Witness as to Principal

(Address)

Surety

ATTEST:

By _____
Attorney-in-Fact

Witness as to Surety

(Address)

(Address)

NOTE: Date of BOND must not be prior to date of Contract. If CONTRACTOR is Partnership, all partners should execute BOND.

IMPORTANT: Surety companies executing BONDS must appear on the Treasury Department's most current list (Circular 570 as amended) and be authorized to transact business in the State where the PROJECT is located.



PROFESSIONAL CERTIFICATION:
 I CERTIFY THAT THESE DOCUMENTS WERE PREPARED
 OR APPROVED BY ME, AND THAT I AM A DULY
 LICENSED PROFESSIONAL ENGINEER UNDER THE
 LAWS OF THE STATE OF MARYLAND.
 LICENSE NO. 31168
 EXPIRATION DATE: 01/12/2025

**KOHLHOSS ROAD WATERLINE
 REPLACEMENT**
 KOHLHOSS ROAD
 POOLESVILLE, MARYLAND

NO.	DATE	DESCRIPTION

DATE: NOV 2023
 CAA PROJECT NO.: 100.062
 DRAWN BY: MS
 CHECKED BY: JA
 SHEET TITLE

**WATERLINE
 PLAN AND
 PROFILE**
 SHEET
C-200



1 KOHLHOSS ROAD PLAN VIEW
 SCALE: 1" = 20'

J:\100.000 Poolesville Genera\100.062 - Kohlhoss Road Waterline\CAAD\DWG\C-200 - WATERLINE PLAN AND PROFILE.dwg 12/14/2023 12:33 PM

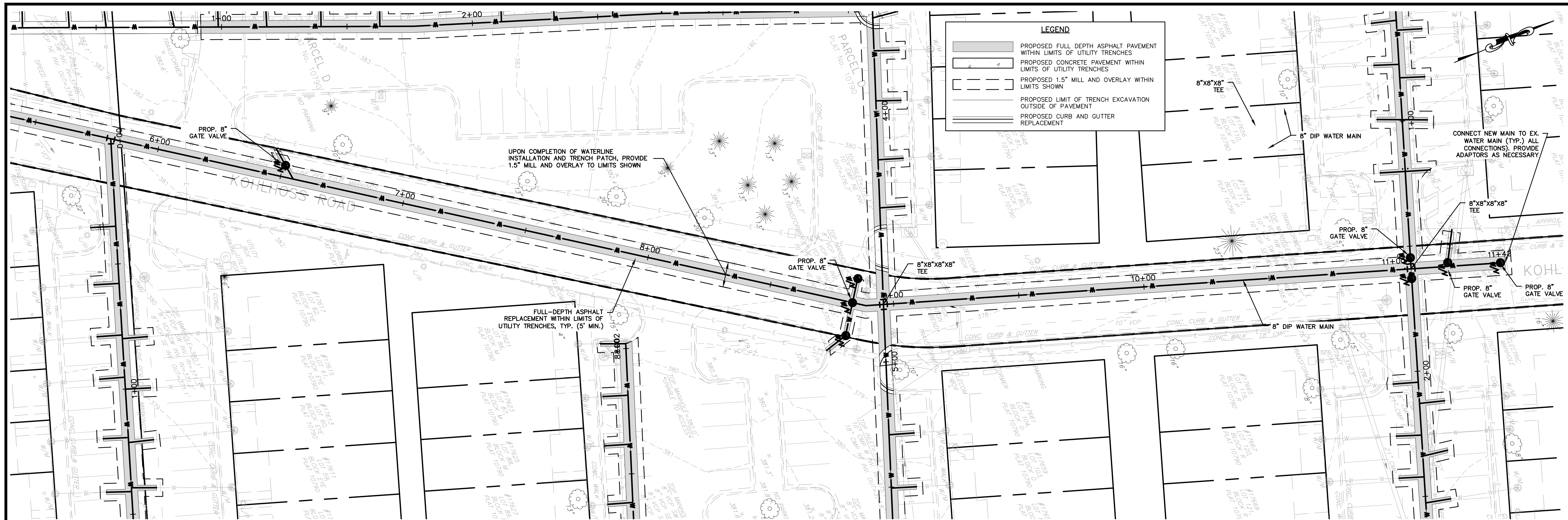

1 KOHLHOSS ROAD PLAN VIEW
SCALE: 1" = 20'

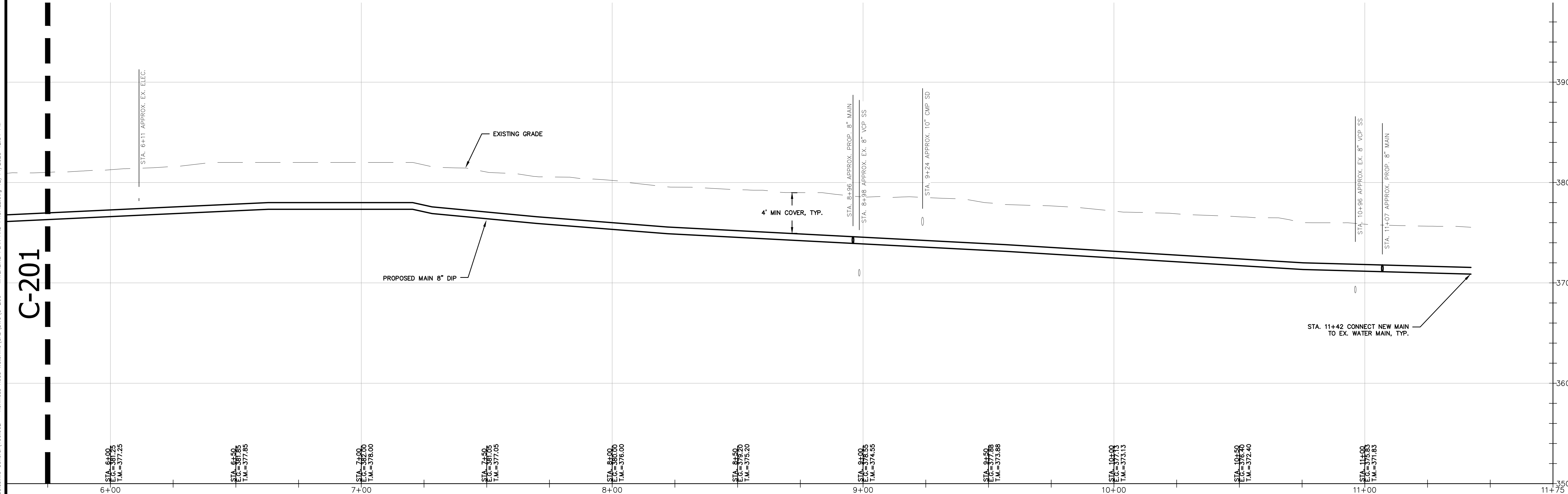

2 KOHLHOSS ROAD PROFILE
SCALE: 1" = 5' (VERT.)
1" = 20' (HOR.)

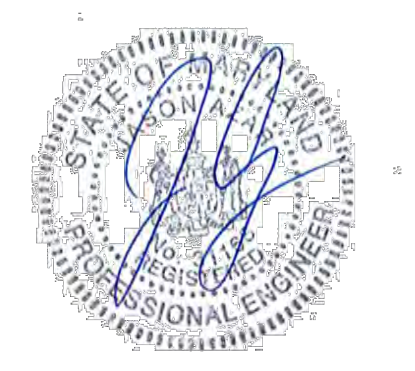

PROFESSIONAL CERTIFICATION:
I CERTIFY THAT THESE DOCUMENTS WERE PREPARED
OR APPROVED BY ME, AND THAT I AM A DULY
LICENSED PROFESSIONAL ENGINEER UNDER THE
LAWS OF THE STATE OF MARYLAND.

LICENSE NO. 31168
EXPIRATION DATE: 01/12/2025

**KOHLHOSS ROAD WATERLINE
REPLACEMENT**
KOHLHOSS ROAD
POOLESVILLE, MARYLAND

NO.	DATE	DESCRIPTION

0 20' 40'
GRAPHIC SCALE

DATE: NOV 2023
CAA PROJECT NO.: 100.062
DRAWN BY: MS
CHECKED BY: JA
SHEET TITLE

**WATERLINE
PLAN AND
PROFILE**

SHEET
C-201

J:\100.000_Poolesville_Germantown\100.062 - Kohlhoss Road Waterline\CAD\DWG\C-200 - WATERLINE PLAN AND PROFILE.dwg 12/14/2023 12:34 PM



PROFESSIONAL CERTIFICATION:
 I CERTIFY THAT THESE DOCUMENTS WERE PREPARED
 OR APPROVED BY ME, AND THAT I AM A DULY
 LICENSED PROFESSIONAL ENGINEER UNDER THE
 LAWS OF THE STATE OF MARYLAND.
 LICENSE NO. 31168
 EXPIRATION DATE: 01/12/2025

**KOHLHOSS ROAD WATERLINE
 REPLACEMENT**
 KOHLHOSS ROAD
 POOLESVILLE, MARYLAND

NO.	DATE	DESCRIPTION

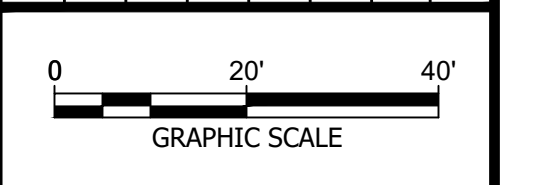

DATE:	NOV 2023
CAA PROJECT NO.:	100.062
DRAWN BY:	MS
CHECKED BY:	JA
SHEET TITLE	

**WATERLINE
 PLAN AND
 PROFILE**
 SHEET
C-202

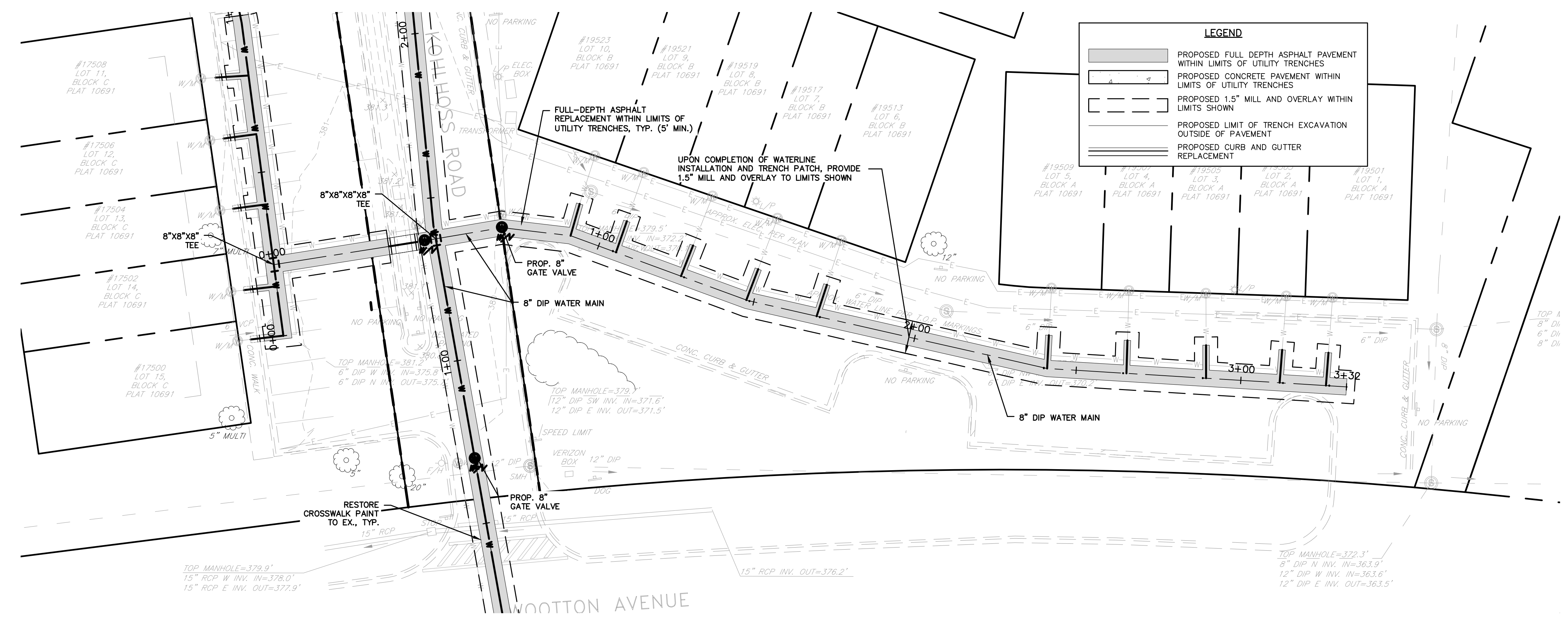

1 KOHLHOSS ROAD PLAN VIEW
 SCALE: 1" = 20'

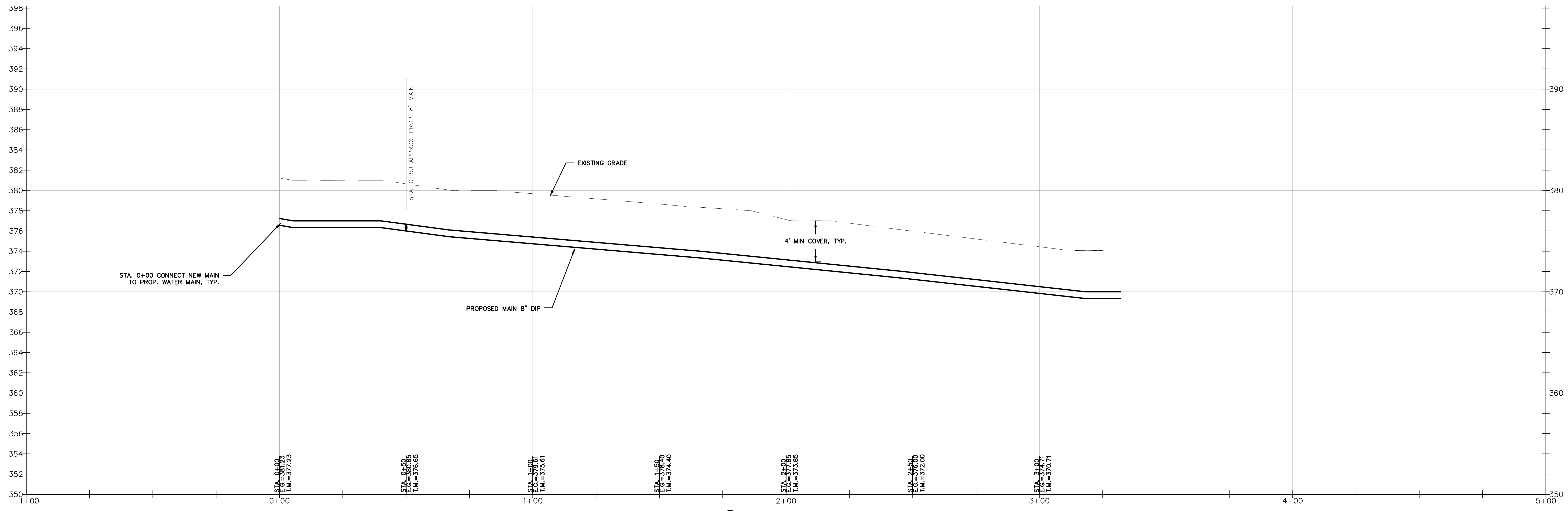

2 KOHLHOSS ROAD PROFILE
 SCALE: 1" = 5' (VERT.)
 1" = 20' (HOR.)

I:\100.000_Poolesville\Gerrard\100.062 - Kohlhoess Road Waterline\CAD\DWG\C-202 - WATERLINE PLAN AND PROFILE.dwg 12/14/2023 12:14 PM



PROFESSIONAL CERTIFICATION:
 I CERTIFY THAT THESE DOCUMENTS WERE PREPARED
 OR APPROVED BY ME, AND THAT I AM A DULY
 LICENSED PROFESSIONAL ENGINEER UNDER THE
 LAWS OF THE STATE OF MARYLAND.
 LICENSE NO. 31168
 EXPIRATION DATE: 01/12/2025

**KOHLHOSS ROAD WATERLINE
 REPLACEMENT**
 KOHLHOSS ROAD
 POOLESVILLE, MARYLAND

LEGEND

- PROPOSED FULL DEPTH ASPHALT PAVEMENT WITHIN LIMITS OF UTILITY TRENCHES
- PROPOSED CONCRETE PAVEMENT WITHIN LIMITS OF UTILITY TRENCHES
- PROPOSED 1.5" MILL AND OVERLAY WITHIN LIMITS SHOWN
- PROPOSED LIMIT OF TRENCH EXCAVATION OUTSIDE OF PAVEMENT
- PROPOSED CURB AND GUTTER REPLACEMENT

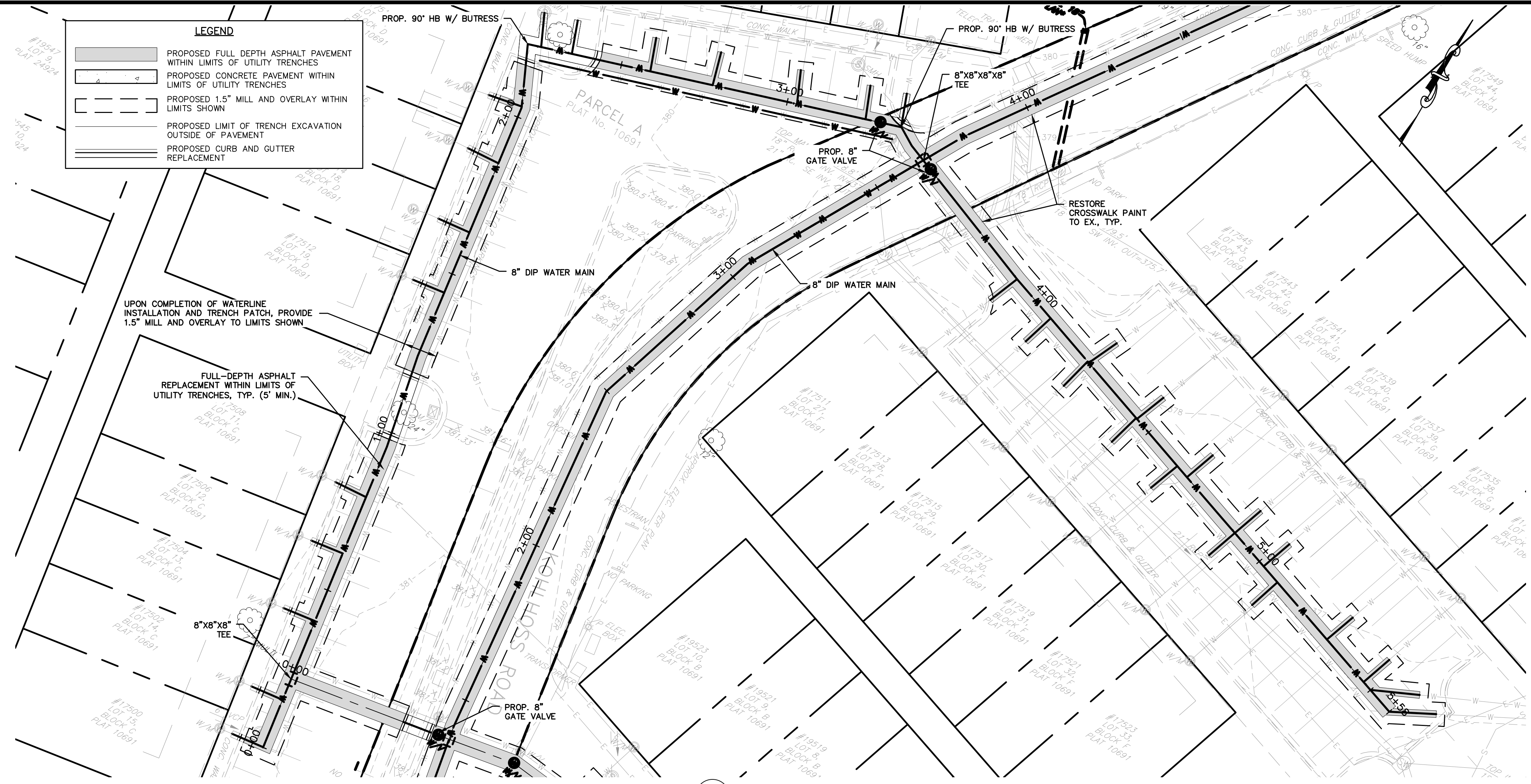

1 KOHLHOSS ROAD PLAN VIEW
 SCALE: 1" = 20'

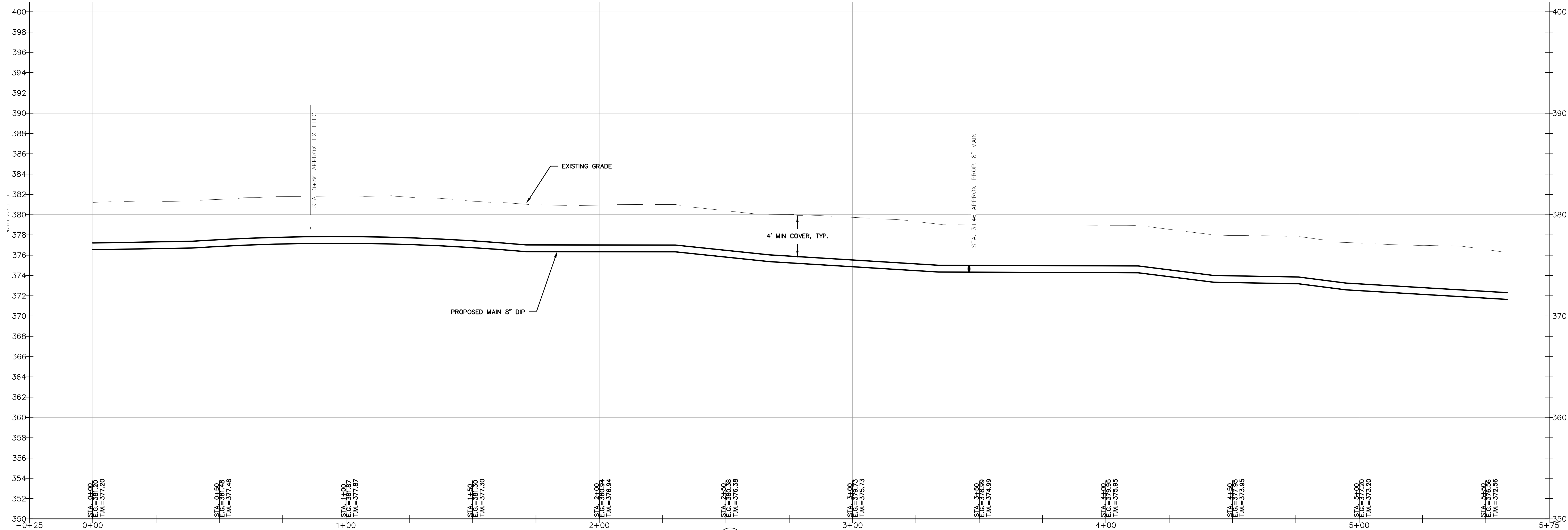

2 KOHLHOSS ROAD PROFILE
 SCALE: 1" = 5' (VERT)
 1" = 20' (HOR.)

NO.	DATE	DESCRIPTION

DATE: NOV 2023
 CAA PROJECT NO.: 100.062
 DRAWN BY: MS
 CHECKED BY: JA

**WATERLINE
 PLAN AND
 PROFILE**

SHEET
C-203

J:\100.000 Poolesville Center\100.062 - Kohlhoess Road Waterline\CAD\DWG\C-203 - WATERLINE PLAN AND PROFILE.dwg 12/14/2023 12:34 PM

J:\100,000 Prod\pds\cerra\100,062 - Kohlhoos Road Waterline\CA\DWG\C-200 - WATERLINE PLAN AND PROFILE.dwg 12/14/2023 12:34 PM

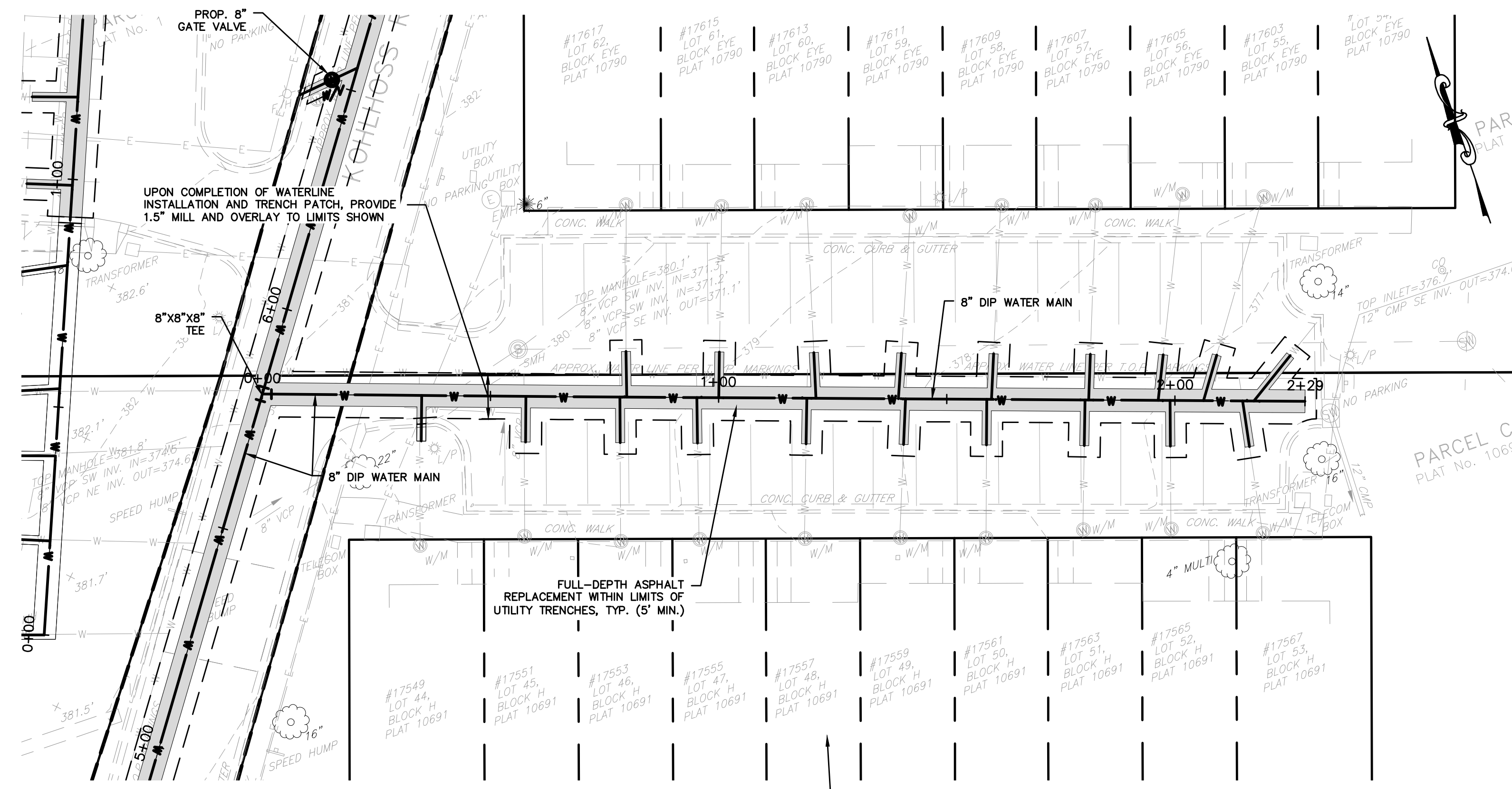

LEGEND	
	PROPOSED FULL DEPTH ASPHALT PAVEMENT WITHIN LIMITS OF UTILITY TRENCHES
	PROPOSED CONCRETE PAVEMENT WITHIN LIMITS OF UTILITY TRENCHES
	PROPOSED 1.5\"/>

1 KOHLHOOS ROAD PLAN VIEW
 SCALE: 1" = 20'
 RESTORE CROSSWALK PAINT TO EX., TYP.

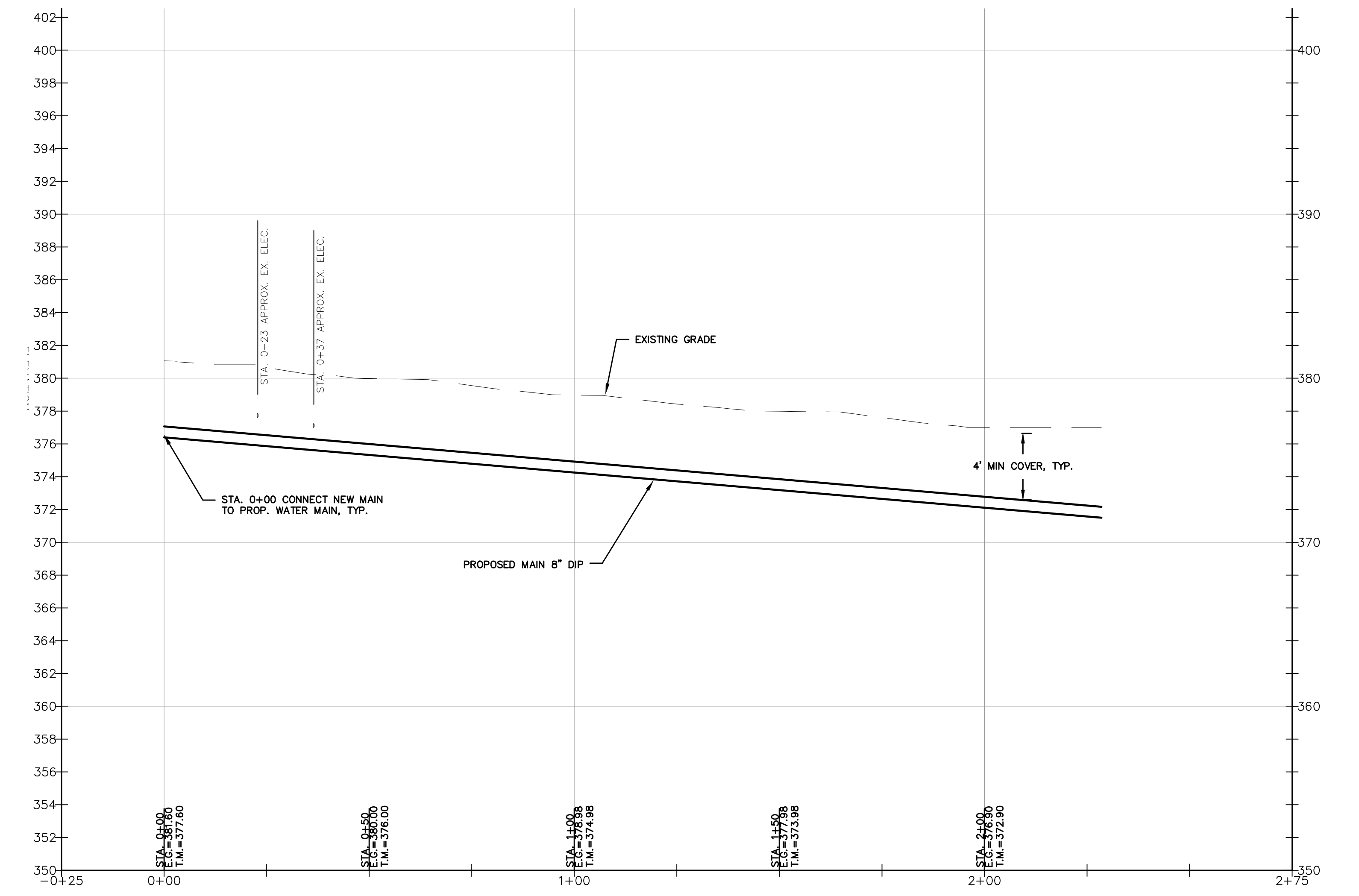

2 KOHLHOOS ROAD PROFILE
 SCALE: 1" = 5' (VERT.)
 1" = 20' (HOR.)

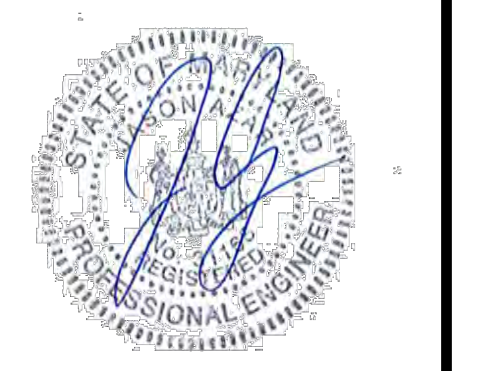

PROFESSIONAL CERTIFICATION:
 I CERTIFY THAT THESE DOCUMENTS WERE PREPARED OR APPROVED BY ME, AND THAT I AM A DULY LICENSED PROFESSIONAL ENGINEER UNDER THE LAWS OF THE STATE OF MARYLAND.
 LICENSE NO. 31168
 EXPIRATION DATE: 01/12/2025

KOHLHOOS ROAD WATERLINE REPLACEMENT
 KOHLHOOS ROAD
 POOLESVILLE, MARYLAND

NO.	DATE	DESCRIPTION

DATE: NOV 2023
 CAA PROJECT NO.: 100.062
 DRAWN BY: MS
 CHECKED BY: JA

WATERLINE PLAN AND PROFILE

SHEET
C-204



PROFESSIONAL CERTIFICATION:
 I CERTIFY THAT THESE DOCUMENTS WERE PREPARED
 OR APPROVED BY ME, AND THAT I AM A DULY
 LICENSED PROFESSIONAL ENGINEER UNDER THE
 LAWS OF THE STATE OF MARYLAND.
 LICENSE NO. 31168
 EXPIRATION DATE: 01/12/2025

**KOHLHOSS ROAD WATERLINE
 REPLACEMENT**
 KOHLHOSS ROAD
 POULESVILLE, MARYLAND

NO.	DATE	DESCRIPTION

DATE: NOV 2023
 CAA PROJECT NO.: 100.062
 DRAWN BY: MS
 CHECKED BY: JA
 SHEET TITLE

SITE DETAILS

**SHEET
 C-208**

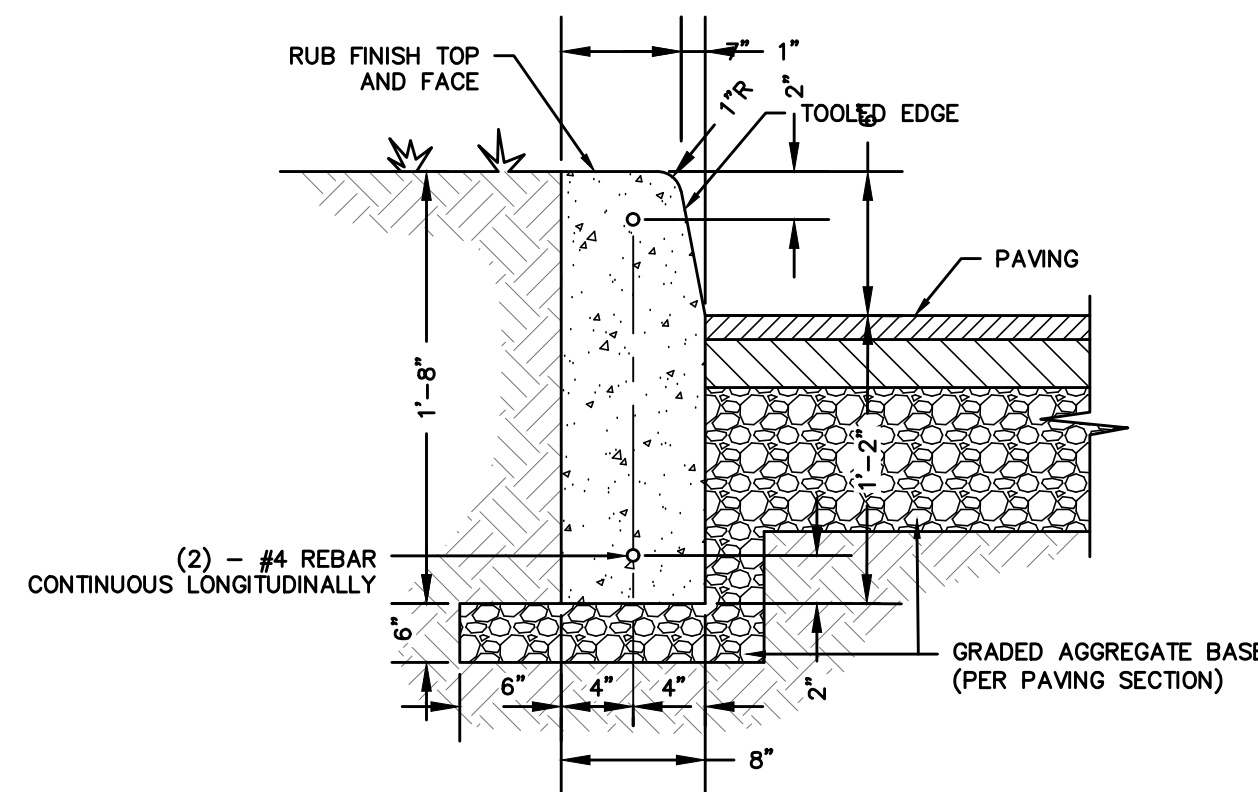

**1 6\"/>
 NOT TO SCALE**

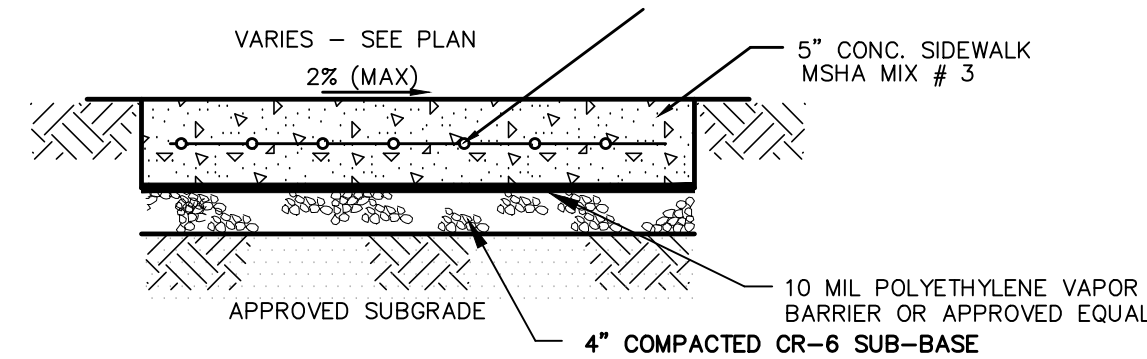

- NOTES:**
- REFER TO MARYLAND STATE HIGHWAY ADMINISTRATION SPECIFICATIONS FOR MATERIALS AND METHODS.
 - EXPANSION JOINT MATERIAL SHALL BE PLACED AROUND POLES, AND HYDRANTS, ETC. WHEN THE SIDEWALK ABUTS ANY RIGID PAVEMENT, SIDEWALK OR STRUCTURE.
 - EXPANSION JOINT MATERIAL SHALL HAVE A MAXIMUM LONGITUDINAL SPACING OF 100 FEET. THE MATERIAL SHALL BE 1/2-INCH PREFORMED CORK, TRIMMED AND SEALED WITH NON-STAINING, TWO-COMPONENT POLYSULFIDE OR POLYURETHANE ELASTOMERIC TYPE SEALANT COMPLYING WITH FS TT-5-00227.
 - SCORE THE CONCRETE TO A DEPTH OF 1/3 THE SLAB THICKNESS TO PROVIDE WEAKENED PLANE TRANSVERSE JOINTS AT 5'-0" INTERVALS, PARALLEL WITH AND PERPENDICULAR TO THE CURBING OR AS INDICATED ON THE SCORING PLAN.

**2 CONCRETE SIDEWALK SECTION
 NOT TO SCALE**

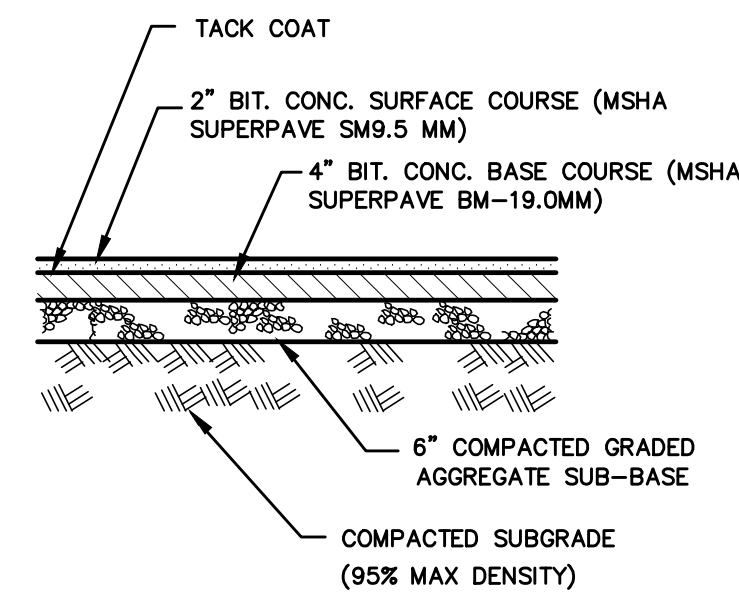

**3 BITUMINOUS PAVEMENT SECTION
 NOT TO SCALE**

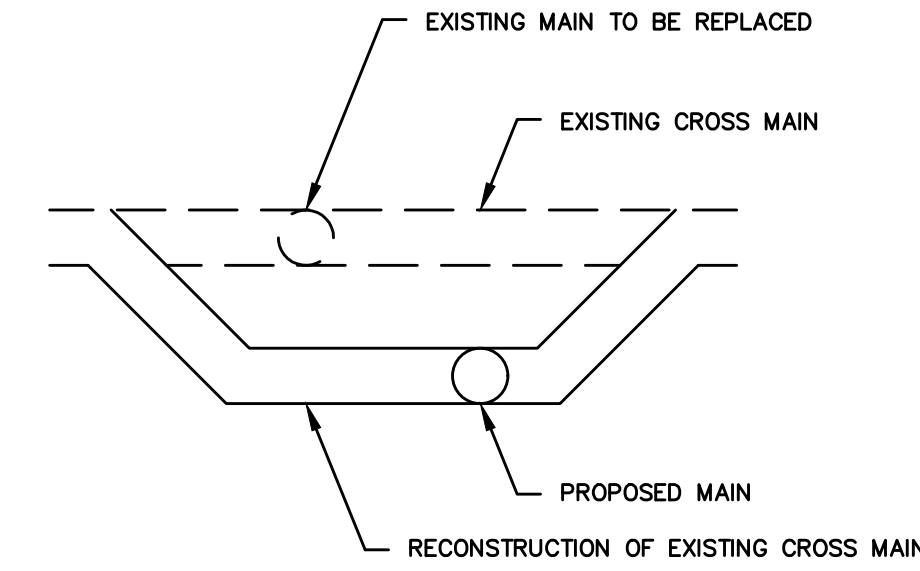

- NOTES:**
- A PORTION OF THE EXISTING CROSS MAIN WILL NEED TO BE RECONSTRUCTED AFTER THE NEW MAIN IS OPERATIONAL, AS SHOWN.

**4 MAIN CROSS CONNECTIONS TYPICAL DETAIL
 NOT TO SCALE**

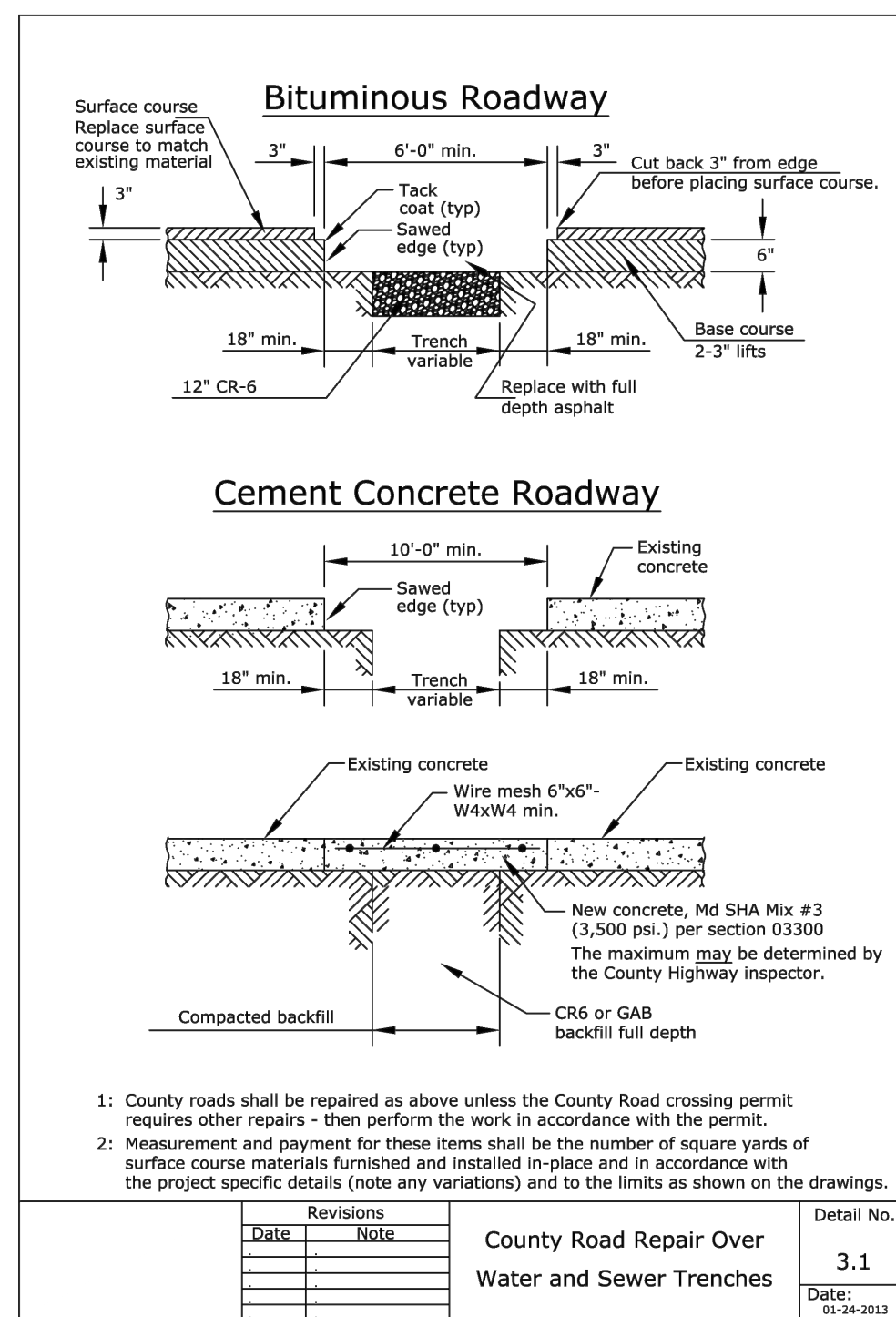
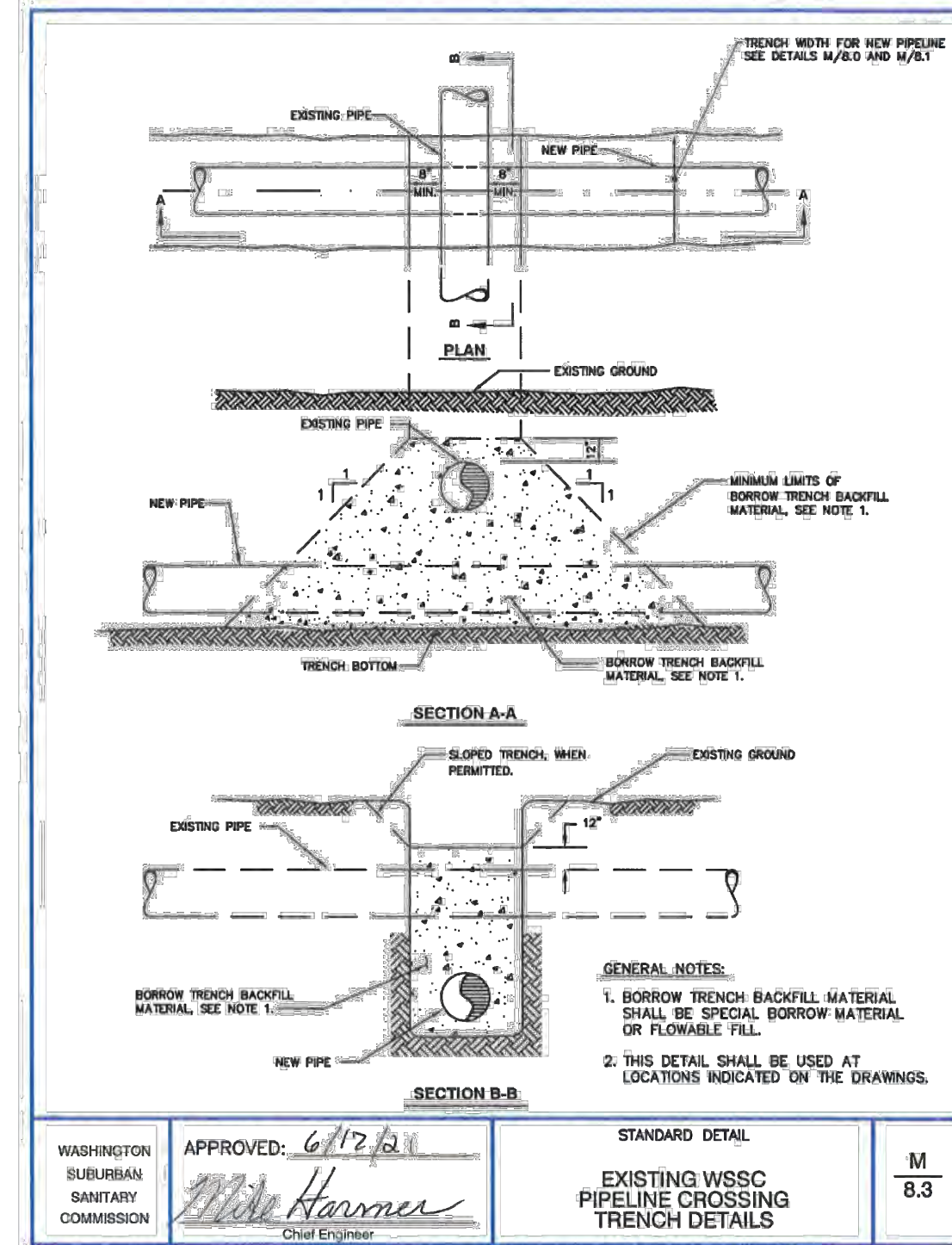

Mechanical Joint Pipe

Nominal Pipe Size	Max. Deflection		Minimum Radius-Feet	
	18 Ft Length	20 Ft Length	18 Ft Length	20 Ft Length
4	31	8.17	35	8.30
6	27	7.13	30	7.13
8	20	5.29	22	5.24
10	20	5.29	22	5.24
12	20	5.29	22	5.24
16	13.5	3.57	15	3.58
18	11	2.92	12	2.86
20	11	2.92	12	2.86
24	9	2.39	10	2.39
36	9	2.39	10	2.39
42	7.5	1.99	8	1.91
48	7.5	1.99	8	1.91

Push-on Joint Pipe

Nominal Pipe Size	Max. Deflection		Minimum Radius-Feet	
	18 Ft Length	20 Ft Length	18 Ft Length	20 Ft Length
4	19	5.03	21	5.00
6	19	5.03	21	5.00
8	19	5.03	21	5.00
10	19	5.03	21	5.00
12	19	5.03	21	5.00
16	11	2.92	12	2.86
18	11	2.92	12	2.86
20	11	2.92	12	2.86
24	11	2.92	12	2.86
36	11	2.92	12	2.86
42	7.5	1.99	8	1.91
48	7.5	1.99	8	1.91

The Above Charts Are in Accordance With AWWA C600.

Curvature of Water Mains

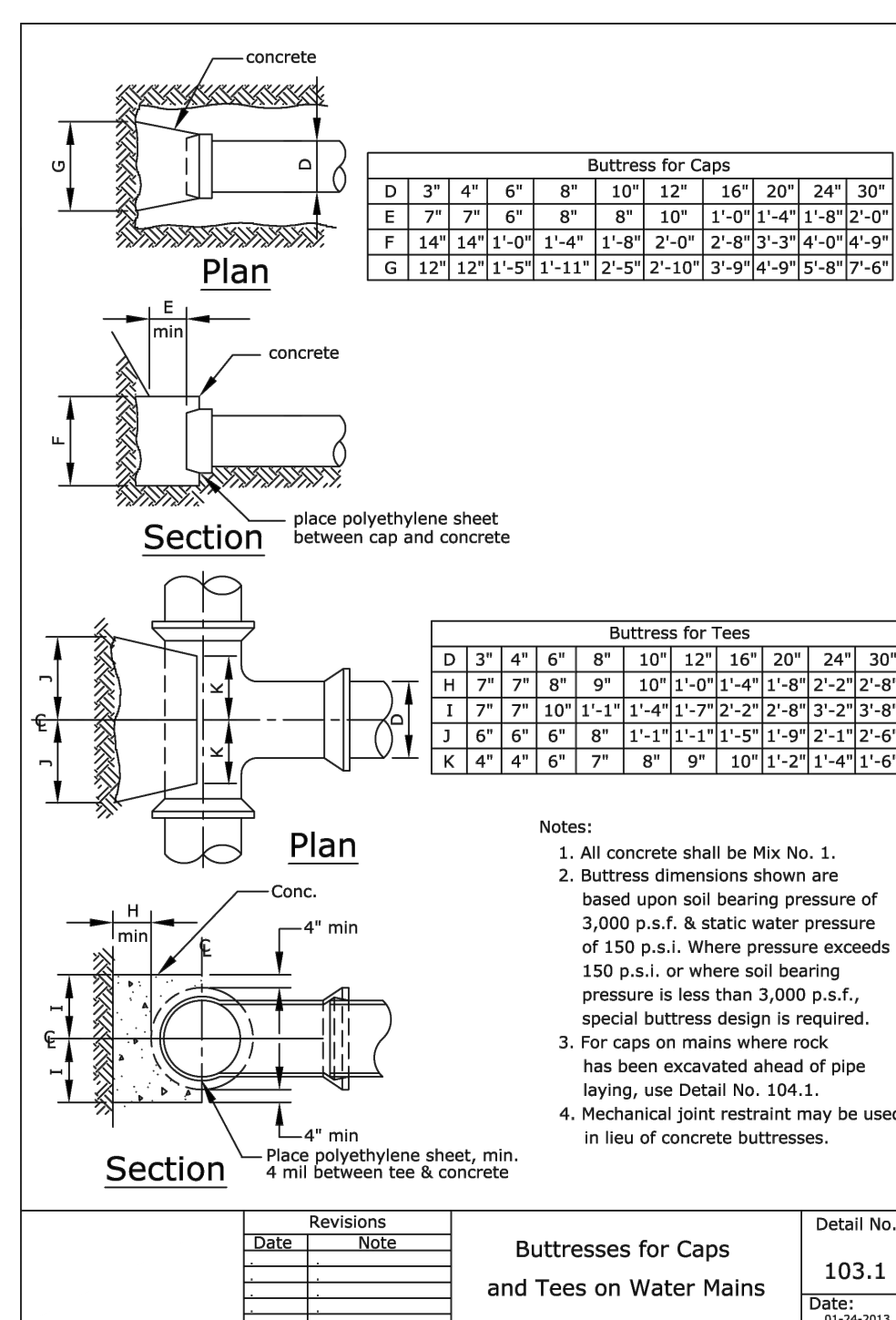
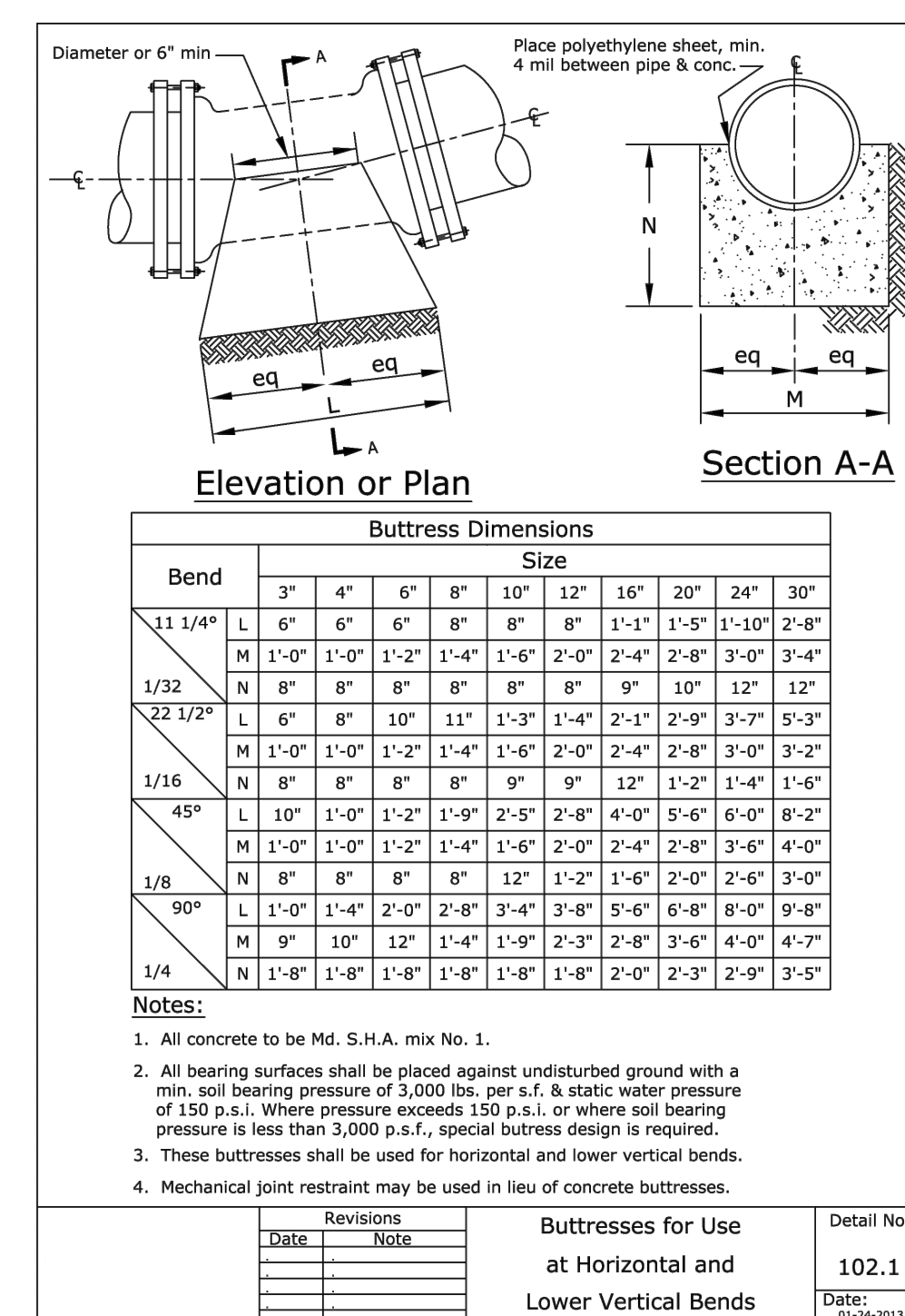

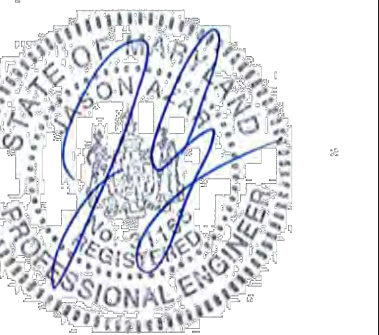

PROFESSIONAL CERTIFICATION:
 I CERTIFY THAT THESE DOCUMENTS WERE PREPARED
 OR APPROVED BY ME, AND THAT I AM A DULY
 LICENSED PROFESSIONAL ENGINEER UNDER THE
 LAWS OF THE STATE OF MARYLAND.
 LICENSE NO. 31168
 EXPIRATION DATE: 01/12/2025

**KOHLHOSS ROAD WATERLINE
 REPLACEMENT**
 KOHLHOSS ROAD
 POOLESVILLE, MARYLAND

**STANDARD DETAIL
 1-INCH, 1-1/2-INCH AND 2-INCH
 WATER HOUSE CONNECTIONS
 FOR INSIDE METERS RURAL
 TYPE PAVING SECTION**

APPROVED: 7-26-21
 Chief Engineer

WASHINGTON SUBURBAN SANITARY COMMISSION

W 5.11

WS11

**STANDARD DETAIL
 1-INCH, 1-1/2-INCH AND 2-INCH
 WATER HOUSE CONNECTIONS AND
 OUTSIDE METER LOCATIONS
 RURAL PAVING SECTIONS**

APPROVED: 7-26-21
 Chief Engineer

WASHINGTON SUBURBAN SANITARY COMMISSION

W 5.14

WS14

**STANDARD DETAIL
 ADJUSTABLE VALVE
 BOX ROUND HEAD
 SLIDING TYPE**

APPROVED: 7-26-21
 Chief Engineer

WASHINGTON SUBURBAN SANITARY COMMISSION

W 2.1

W21

**STANDARD DETAIL
 METHOD OF RESTRAINING
 FIRE HYDRANT TO MAIN
 12-INCH AND SMALLER**

APPROVED: 7-26-21
 Chief Engineer

WASHINGTON SUBURBAN SANITARY COMMISSION

B 2.1

B21

**NOTE:
 NO STAINLESS STEEL**

**Tapping Sleeve
 and Valve
 Installation**

Detail No. 117.1
 Date: 01-24-2013

Section A-A

Concrete shall be Mix. No. 1.

Buttress Dimensions in Inches						
B	4	6	8	10	12	16
C	17	17	23	29	34	45
D	10	12	16	20	24	32

**Cap and Blow-off
 at End of Main
 Modified**

Detail No. 116.1
 Date: 01-24-2013

NO.	DATE	DESCRIPTION

DATE: NOV 2023
 CAA PROJECT NO.: 100.062
 DRAWN BY: MS
 CHECKED BY: JA
 SHEET TITLE

SITE DETAILS

SHEET

C-209

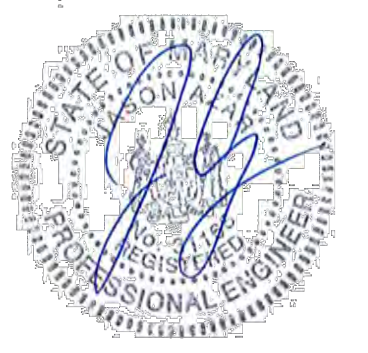

PROFESSIONAL CERTIFICATION:
 I CERTIFY THAT THESE DOCUMENTS WERE PREPARED
 OR APPROVED BY ME, AND THAT I AM A DULY
 LICENSED PROFESSIONAL ENGINEER UNDER THE
 LAWS OF THE STATE OF MARYLAND.
 LICENSE NO. 31168
 EXPIRATION DATE: 01/12/2025

**KOHLHOSS ROAD WATERLINE
 REPLACEMENT**
 KOHLHOSS ROAD
 POOLESVILLE, MARYLAND

GENERAL NOTES

1. ALL TEMPORARY TRAFFIC CONTROL MEASURES SHALL BE SETUP PRIOR TO STARTING ALL WORK AND TAKEN DOWN AT THE END OF EACH WORK DAY.
2. ALL TEMPORARY TRAFFIC CONTROL MEASURES SHALL BE IMPLEMENTED AND MAINTAINED PER THE LATEST MARYLAND STATE HIGHWAY ADMINISTRATION MANUAL ON UNIFORM TRAFFIC CONTROL DEVICES (MDMUTC) AND FEDERAL HIGHWAY ADMINISTRATION MANUAL ON UNIFORM TRAFFIC CONTROL DEVICES (MUTCD).
3. THE CONTRACTOR SHALL MAINTAIN ACCESS TO ALL DRIVEWAYS LOCATED WITHIN THE TEMPORARY TRAFFIC CONTROL AREA ALONG THE AFFECTED ROADWAY(S). CONTRACTOR SHALL NOTIFY ALL AFFECTED PROPERTY OWNERS OF THE INTENDED WORK A MINIMUM OF 72 HOURS IN ADVANCE. ALL TEMPORARY DRIVEWAY CLOSURE TIMEFRAMES SHALL BE COORDINATED WITH THE PROPERTY OWNER A MINIMUM OF 72 HOURS IN ADVANCE.
4. ANY MODIFICATIONS TO THE TEMPORARY TRAFFIC CONTROL MEASURES MUST BE APPROVED BY THE SH&A TRAFFIC CONTROL INSPECTOR AND TOWN OF POOLESVILLE INSPECTOR/REPRESENTATIVE IN WRITING.
5. THE CONTRACTOR SHALL BE RESPONSIBLE FOR SCHEDULING ALL PRE-CONSTRUCTION MEETINGS AND INSPECTIONS RELATED TO THE TEMPORARY TRAFFIC CONTROL PERMIT.
6. ALL ROADWAY PAVEMENT MARKINGS THAT ARE REMOVED/DAMAGED AS A RESULT OF THE PROPOSED WORK SHALL BE RESTORED AT THE CONTRACTORS EXPENSE.

PHASING NOTES

WOOTTON AVENUE:

1. INSTALL TEMPORARY TRAFFIC CONTROL SIGNAGE, CHANNELIZING DEVICES, AND FLAGGERS FOR SINGLE-LANE OPERATION AS SHOWN ON PLAN.
 2. BEGIN WATER LINE CONNECTION TRENCH EXCAVATION AND EXISTING DRIVEWAY PAVEMENT REMOVAL. CONTRACTOR SHALL PROVIDE NECESSARY SHEETING AND SHORING FOR INSTALLATION.
 3. AT THE END OF EACH WORK DAY STEEL PLATES AND ASSOCIATED ADVANCED WARNING SIGNS MUST BE USED TO COVER EXCAVATED TRENCH AREA WITHIN ROADWAY. CONTRACTOR SHALL TAKE DOWN FLAGGER OPERATION SIGNAGE AND MOVE CHANNELIZING DEVICES TO EDGE OF ROADWAY TO PROVIDE (2) TEN-FOOT WIDE MINIMUM TRAVEL LANES.
 4. ONCE ALL WATER LINE CONNECTION, DRIVEWAY ENTRANCE, AND ROADWAY PAVEMENT RESTORATION WORK HAS BEEN COMPLETED WITHIN PHASE 1 WORK ZONE, CONTRACTOR SHALL RESTORE ANY ROADWAY PAVEMENT MARKINGS, SIGNAGE, AND PAVEMENT THAT WAS DAMAGED OR REMOVED AS PART OF THE PROPOSED WORK TO EXISTING CONDITIONS PER MSHA STANDARDS AND SPECIFICATIONS, WITH WRITTEN APPROVAL FROM THE TOWN OF POOLESVILLE INSPECTOR/REPRESENTATIVE. CONTRACTOR SHALL REMOVE ALL TEMPORARY TRAFFIC CONTROL DEVICES.
- REPEAT STEPS 1 THRU 3 UNTIL WORK HAS BEEN COMPLETED WITHIN EAST F STREET PHASE 1 WORK ZONE.

TEMPORARY TRAFFIC CONTROL TYPICAL APPLICATION

NOTES:
 1. MAXIMUM SPACING BETWEEN CHANNELIZING DEVICES:
 TAPER CHANNELIZATION - SHALL BE EQUAL IN FEET TO THE POSTED SPEED LIMIT FOR POSTED SPEEDS EQUAL TO OR LESS THAN 40 MPH AND 40 FEET FOR POSTED SPEEDS GREATER THAN 40 MPH.
 TANGENT CHANNELIZATION - SHALL BE EQUAL IN FEET TO TWICE THE POSTED SPEED LIMIT IN THE BUFFER AND EQUAL IN FEET TO THE POSTED SPEED LIMIT IN THE WORK AREA AS SHOWN IN THE FIGURE. SPACING SHALL BE 80 FEET IN THE BUFFER AND 40 FEET ADJACENT TO THE WORK AREA FOR POSTED SPEEDS GREATER THAN 40 MPH.

2. THE MINIMUM BUFFER LENGTH (BL) SHALL BE AS FOLLOWS:

PREVAILING SPEED (MPH)	LENGTH (FEET)
20	115
25	155
30	200
35	250
40	305
45	360
50	425
55	495
60	570
65	645
70	730
75	820

REFER TO LATEST PART VI OF THE MUTCD FOR ADDITIONAL SPEED/BUFFER LENGTHS AND ADJUSTMENTS TO BUFFER LENGTH DUE TO THE EFFECT OF GRADE OR STOPPING AND VARIATION FOR TRUCKS.

3. REFER TO STANDARD NO. MD 104.01-80 (TAPER LENGTH CRITERIA TABLE) FOR MINIMUM TAPER LENGTHS.

Maryland Department of Transportation
STATE HIGHWAY ADMINISTRATION
 STANDARDS FOR HIGHWAYS AND INCIDENTAL STRUCTURES

TYPICAL APPLICATION NOTES

STANDARD NO. MD 104.01-81

TEMPORARY TRAFFIC CONTROL TYPICAL APPLICATION

IMPORTANT:
 THIS DRAWING SHALL BE USED IN COMBINATION WITH THE GENERAL NOTES AND STANDARD DETAILS NO. MD 104.01-18 AND STANDARD DETAILS NO. MD 104.01-19 AND MD 104.01-21.

NOTES:
 1. 36" CONES OR TALL WEIGHTED CONES SHALL BE USED IN THE MERGING TAPER.
 2. 36" CONES OR TALL WEIGHTED CONES SHALL BE USED ADJACENT TO THE WORK AREA.
 3. PROTECTION VEHICLE, WITH FLASHING LIGHTS, SHOULD BE USED TO PROTECT THE WORK AREA AS SHOWN IN THE FIGURE. WHILE ALLOWING FOR THE ROLL AHEAD DISTANCE ANTICIPATED WITH IMPACTS.
 4. REFER TO GENERAL NOTE 1.8 FOR GUIDANCE ON USING CHANNELIZING DEVICES TO DELINEATE THE EDGE OF THE ROADWAY.
 5. TALL WEIGHTED CONES - CONES 42" TALL WITH A NARROW, WEIGHTED BASE - SEE STANDARD SPECIFICATION 104.14.
 6. THIS TYPICAL APPLICATION DOES NOT APPLY TO PAVING OPERATIONS; BUT CAN BE USED AT THE DISCRETION OF THE ENGINEER.

KEY:
 CHANNELIZING DEVICES
 DIRECTION OF TRAFFIC
 WORK AREA
 ARROW PANEL
 TRUCK OR TRAILER-TRUCK MOUNTED ATTENUATOR (T-MATA)
 SAFETY VEHICLE

OPTIONAL PROTECTION VEHICLE (PV)

Maryland Department of Transportation
STATE HIGHWAY ADMINISTRATION
 STANDARDS FOR HIGHWAYS AND INCIDENTAL STRUCTURES

CHANNELIZATION DEVICE SPACING
 EQUAL TO OR LESS THAN 40 MPH

STANDARD NO. MD 104.01-30 B

TEMPORARY TRAFFIC CONTROL TYPICAL APPLICATION

IMPORTANT:
 THIS DRAWING SHALL BE USED IN COMBINATION WITH THE GENERAL NOTES AND STANDARD DETAILS NO. MD 104.01-18 AND STANDARD DETAILS NO. MD 104.01-19 AND MD 104.01-21.

NOTES:
 1. FLAGGER SHALL NEVER BE STATIONED MORE THAN 1000' AWAY FROM THE ADVANCED WARNING SIGN.
 2. THE ENGINEER SHALL CONSIDER ADDITIONAL ADJACENT LANE CLOSURES WHEN THE POSSIBILITY OF UNPLANNED TRAVELWAY ENCROACHMENTS EXISTS.

KEY:
 CHANNELIZING DEVICES
 FACE OF SIGN
 DIRECTION OF TRAFFIC
 WORK SITE
 FLAGGER

OPTIONAL FOR 15 MIN. OR DAYTIME APPLICATIONS

Maryland Department of Transportation
STATE HIGHWAY ADMINISTRATION
 STANDARDS FOR HIGHWAYS AND INCIDENTAL STRUCTURES

FLAGGING OPERATION 2-LANE, 2-WAY
 EQUAL TO OR LESS THAN 40 MPH

STANDARD NO. MD 104.02-10

TEMPORARY TRAFFIC CONTROL TYPICAL APPLICATION

SIGN SPACING CHART
 STANDARD TYPICAL CONTROL OPERATIONS

SPEED (MPH)	MINIMUM DISTANCE FROM TAPER END TO SIGN A	MINIMUM DISTANCE FROM SIGN B TO SIGN C	MINIMUM DISTANCE FROM SIGN D TO SIGN E	MINIMUM COMBINED ADVANCED WARNING
≤ 25	200'	200'	200'	600'
26 - 35	300'	300'	300'	900'
36 - 40	500'	500'	500'	1500'
41 - 65	800'	700'	100'	2600' (1/2 MILE)
66 - 80	1000'	500'	100'	2600' (1/2 MILE)

* SPEED LIMIT OR PREVAILING TRAVEL SPEED, WHICHEVER IS HIGHER.

BELOW EXAMPLE: TWO LANES, ONE-WAY ROADWAY / SPEED LIMIT IS 35 MPH / PREVAILING SPEED IS 38 MPH (USE 40 MPH)

Maryland Department of Transportation
STATE HIGHWAY ADMINISTRATION
 STANDARDS FOR HIGHWAYS AND INCIDENTAL STRUCTURES

STANDARD NO. MD 104.01-82

TEMPORARY TRAFFIC CONTROL TYPICAL APPLICATION

ROADSIDE SIGN / SIGN SUPPORT PLACEMENT

NO SH&A OFFICE OF TRAFFIC AND SAFETY MANUALLY A LIST OF APPROVED PORTABLE SIGN SUPPORTS, SIGN SUPPORTS SHALL BE USED AT THE DISCRETION OF THE ENGINEER. MANUFACTURER'S RECOMMENDATION TO MEET MASH OR MCMPP 300 LEVEL 3, CRITERIA.

PORTABLE

RURAL DISTRICT

URBAN DISTRICT

* BREAKAWAY WOOD SUPPORTS OF SQUARE, SQUARE METAL POSTS TYPICAL. REFER TO MD 104.01-17B FOR WOOD SUPPORT AND MD 104.01-17C FOR TUBULAR STEEL BREAKAWAY INFORMATION.

Maryland Department of Transportation
STATE HIGHWAY ADMINISTRATION
 STANDARDS FOR HIGHWAYS AND INCIDENTAL STRUCTURES

ROADSIDE SIGN SUPPORTS
 PLACEMENT

STANDARD NO. MD 104.01-17 A

TEMPORARY TRAFFIC CONTROL TYPICAL APPLICATION

PROJECT LIMITS SIGNS

NOTES:
 1. DRAWING SHOWS SIGNING FOR TWO-LANE, TWO-WAY. FOR MULTILANE UNDIVIDED HIGHWAYS USE THIS SAME DRAWING.
 2. FOR MULTILANE DIVIDED HIGHWAYS, ERECT SIGNS ON BOTH SIDES OF THE WORK AFFECTED ROADWAY.
 3. THE SIGN DISTANCE (S) SHALL BE STATED TO THE NEAREST WHOLE MILE.
 4. WHERE HIGHWAY ALIGNMENT CHANGES OCCUR THROUGHOUT THE WORK AREA DUE TO PHASE OF WORK CHANGES, A SUPPLEMENTAL SIGN SPECIFYING NEW TRAFFIC PATTERN (VCS-101), SHALL BE MOUNTED BENEATH THE LENGTH OF WORK SIGN. THE SUPPLEMENTAL SIGN SHALL REMAIN IN PLACE FOR A MAXIMUM OF 30 DAYS UNLESS OTHERWISE DIRECTED BY THE ENGINEER.
 5. THIS DRAWING DOES NOT APPLY TO MOBILE OPERATIONS.

KEY:
 SIGN SUPPORT
 FACE OF SIGN

Maryland Department of Transportation
STATE HIGHWAY ADMINISTRATION
 STANDARDS FOR HIGHWAYS AND INCIDENTAL STRUCTURES

PROJECT LIMITS SIGNS

STANDARD NO. MD 104.01-33

STANDARD DETAIL

METHOD 2 - SHALL BE USED FOR EXISTING CONCRETE PAVEMENT SECTIONS, REGARDLESS OF SPEED.
 METHOD 1 - FOR SPEEDS EQUAL TO OR LESS THAN 40 MPH (SEE DETAIL BELOW)

APPROACH PLATE AND ENDING PLATE OF SUBORDINAL PLACEMENT SHALL BE ATTACHED TO THE ROADWAY BY A MINIMUM OF 2 INCHES ON EACH CORNER OF THE PLATE. SHALL BE 1/2 INCH THICKNESS, 3/8 INCH DEPTH, 1/2 INCH WIDE AND 1/2 INCH HIGH. SHALL BE CAPABLE OF WITHSTANDING 10,000 LBS. PER LINEAL FOOT OF ROADWAY. SHALL BE CAPABLE OF WITHSTANDING 10,000 LBS. PER LINEAL FOOT OF ROADWAY. SHALL BE CAPABLE OF WITHSTANDING 10,000 LBS. PER LINEAL FOOT OF ROADWAY. SHALL BE CAPABLE OF WITHSTANDING 10,000 LBS. PER LINEAL FOOT OF ROADWAY.

STEEL PLATE DETAIL (METHOD 2, EQUAL TO OR LESS THAN 40 MPH)

THE FOLLOWING TABLE SHOWS THE ADJUSTED MINIMUM THICKNESS OF STEEL PLATE BRIDGING REQUIRED FOR A GIVEN FRENCH WITH A 3/8 OR 1/2 INCH STEEL PLATE

FRENCH WIDTH	MINIMUM PLATE THICKNESS
1.5'	SEE NOTE #3
2.5'	SEE NOTE #3

NOTES:
 1. STEEL PLATE USAGE WILL BE INCIDENTAL TO THE WORK BEING PROTECTED UNLESS AN ITEM FOR STEEL PLATES IS INCLUDED IN THE CONTRACT SCHEDULE OF PRICES.
 2. STEEL PLATE INSTALLED SHALL HAVE A MAXIMUM ONE INCH DEFLECTION. STEEL PLATES SHALL BE WELDED TOGETHER BY A LICENSED WELDER.
 3. FOR FRENCH WIDTHS EQUAL TO OR GREATER THAN 5 FT., STEEL PLATE AND SUPPORT SYSTEM SHALL BE DESIGNED AND STAMPED BY A PROFESSIONAL ENGINEER LICENSED IN THE STATE OF MARYLAND AND APPROVED BY THE SH&A ENGINEER.
 4. STEEL PLATE BRIDGING IS NOT ALLOWED ON EXPRESSWAYS/FREEWAYS.
 5. ANCHORS ARE TO BE A MIN. OF 6 IN. IN LENGTH.

Maryland Department of Transportation
STATE HIGHWAY ADMINISTRATION
 STANDARDS FOR HIGHWAYS AND INCIDENTAL STRUCTURES

STEEL PLATE
 METHOD 2, EQUAL TO OR LESS THAN 40 MPH

STANDARD NO. MD 104.01-86

TEMPORARY TRAFFIC CONTROL TYPICAL APPLICATION

TAPER LENGTH CRITERIA TABLE

SPEED (S) IN MPH	WIDTH OF OFFSET (W) IN FEET											
	1	2	3	4	5	6	7	8	9	10	11	12
25	11	21	32	42	53	63	73	84	94	105	115	125
30	15	30	45	60	75	90	105	120	135	150	165	180
35	21	41	62	82	103	123	143	164	184	205	225	245
40	27	54	80	107	134	160	187	214	240	267	294	320
45	45	90	135	180	225	270	315	360	405	450	495	540
50	50	100	150	200	250	300	350	400	450	500	550	600
55	55	110	165	220	275	330	385	440	495	550	605	660
60	60	120	180	240	300	360	420	480	540	600	660	720
65	65	130	195	260	325	390	455	520	585	650	715	780
70	70	140	210	280	350	420	490	560	630	700	770	840

TYPE OF TAPER

W

L

MARYLAND DEPARTMENT OF TRANSPORTATION
STATE HIGHWAY ADMINISTRATION
 STANDARDS FOR HIGHWAYS AND INCIDENTAL STRUCTURES

TAPER LENGTH CRITERIA TABLE

STANDARD NO. MD 104.01-80

NO.	DATE	DESCRIPTION

DATE: NOV 2023
 CAA PROJECT NO.: 100.062
 DRAWN BY: MS
 CHECKED BY: JA
 SHEET TITLE

TEMPORARY TRAFFIC CONTROL NOTES AND DETAILS

SHEET
C-800

